

Service-Handbuch
Service Booklet

Scrubmaster B 115 R

(7090.11/21/35/41/51/81/91)

Schulung/Training
Fehlersuche/Troubleshooting
Einstelldaten/Adjustments



Contents

1	Information	6
2	General Information	7
	2.1 Settings	9
	2.1.1 Connection with the Diagnosis-Computer	11
	2.1.2 Flashing of the control unit	13
	2.1.3 Connection schemes with the different interfaces	15
	2.2 Short Description	16
	2.2.1 Deactivating Vacuuming / Dirty Water Tank Full	17
	2.2.2 Home Position of the Machine	18
	2.2.3 Seat Contact Switch (3.6.6.4.)	19
	2.2.4 Introduction to Programming	21
	2.2.5 Reset Last Error Which Occurred in the Start Screen	25
3	Technical Data	26

Contents

4	Maintenance Intervals	29
	4.1 Hako System Maintenance (Customer)	30
	4.2 Hako System Maintenance I	31
	4.3 Hako System Maintenance II	32
	4.4 Hako System Maintenance S	33
5	Cleaning Programs	34
6	Machine Settings	37
	6.1 Basic Settings	37
	6.1.1 Machine Type	37
	6.1.2 Cleaning Units	39
	6.1.3 Battery Setting	41
	6.1.4 Charger	44
	6.2 Settings On Customer Request (PPV)	46

Contents

7	Mechanical Components	51
	7.1 Squeegee	51
	7.2 Disk Brush Head	56
	7.3 Cylindrical Brush Head	56
	7.3.1 Adjustment cylindrical brush head	57
	7.4 Brush Head Lifting Unit	59
	7.4.1 Potentiometer in the Brush Head Lifting Unit	62
8	Water Pump	63
	8.1 Water Quantities	64
	8.2 Water Pump Standstill Recognition	65
9	Drive Control Units	66
	9.1 ATECH / ZAPI Drive control unit (DC-Motor)	67
	9.1.1 Automatic Monitoring of Components	69
	9.1.2 Diagnosis LED for Drive Module (ZAPI)	70
	9.1.3 Explanations of Error Messages	71
	9.2 DMC (AC-Motor)	88
	9.2.1 Description of the connectors	88
	9.2.2 Error-Codes on the DMC Control unit (AC Motor)	90

Contents

	9.3 Drivemotor and Gearbox DC and AC	96
10	Error Reference Chart with Information on Service Display	98
	10.1 Service Counter 3.3.1.1.	102
11	Brakes	105
	11.1 Adjustment of Brake (DC-Motor)	106
	11.2 Brake of the AC Motor	107
12	Options	108
	12.1 Silence Kit	109
	12.2 Acoustic Warning Signal	112
	12.3 Chemical Dosage	113
	12.4 Scrubbing-Vacuum Tool	125
13	Real-Time Clock (RTC)	130
14	Notes	133

1. Information

Attention:

- All work on the vehicle may only be completed after disconnection of the power supply (disconnect the battery plug) with the exception of the current and voltage measurements.
- When changing high current fuses, only loosen the screws. Never unscrew the screws completely, otherwise there is a risk of short circuit. Insert the new high current fuses fully, i.e. evenly under the screws.
- Following repairs, the starting current and operating current must be measured in order to discover any potential faults.
- The legally binding, generally applicable safety and accident prevention regulations must be observed when performing any work on the vehicles.

2. General Information

as part of a restyling of the Hako brand names, the name of the scrubber-driers has been changed from "Hakomatic" to "Scrubmaster". In this document both names are used equally, because this document is also valid for machines which have been introduced in the market before the renaming

The Scrubmaster B115 R is equipped with a service indicator in the operating hour counter display. After switching the key switch on, a four-character code appears for approx. 3 seconds in the display which indicates the software version (e.g. 1.001), possibly another four-character code which indicates the last fault which has occurred followed by the operating hour counter.

As soon as a fault occurs, the open-ended wrench lights up in the display and the machine beeps. The current **diagnostic code** (four-character alphanumeric code in the service indicator) **appears with flashing points between the characters**. Only when these criteria are fulfilled is the error currently pending!

There is no diagnostic code which contains a "ZERO".

2. General Information

B115 R

The Scrubmaster B115 R is available with working widths between 65 cm and 90 cm. The 7090.35/41/51 models require an external charger; the 7090.11/21/81/91 models are equipped with an integrated charger.

The 7090.51 model is equipped with a 65 cm disk brush unit; the 7090.11/35 models are equipped with a 75 cm disk brush unit. The 7090.21/41 models are provided with a cylindrical brush unit with a working width of 70 cm.

The working width of the disk brush unit (7090.81) is 90 cm and working width of the cylindrical brush unit (7090.91) is 85 cm.

The chargers are provided with a separate operating manual enclosed with the device and which contains descriptions of the operating and fault conditions of the charger.

2.1 Settings

The relevant settings can be defined in the machine's Configuration menu. The diagnostics connector with order number PN 03006790 is required in order to define these settings.

The settings to be defined include:

- Machine type / Cleaning unit
- TSG (total discharge signal transducer) / Battery type
- Options
- Deletion of the display of the last error on completion of repairs
- Programmable program versions (PPV)
- Fixed program versions (FPV), cleaning programs

These settings can also be entered via the diagnostics system using a service PC. In this case, a PC with min. 1x USB 2.0 and 1x RS232 port, the diagnostic cable PN 03502110 and CAN interface PN 03501750 (alternative the service interface PN 03502430) represent the hardware required. Windows XP or Windows 7 must be installed as the operating system on the PC. The diagnostics software required for the Scrubmaster B115R is contained on the current Hako Diagnosis CD-ROM (85-00-2144).

2.1 Settings

A new machine control unit is delivered from spares stock without machine software. Only the Boot-loader is pre-installed on the control module. This can be recognized by the jumping “F” in the hour meter display of the dashboard, after the control module is mechanically and electrically installed in the machine and the keyswitch is switched “on”.

Therefore, after mechanical and electrical installation of the control module, the machine software must be flashed on the control module. This requires the same preconditions (hard- and software), like for the diagnosis of the machine.

2.1.1 Connection with the Diagnosis-Computer

To activate the control unit PN 01273590 for a Scrubmaster B115 R after a replacement, the following components are necessary:

- up to date Hako Diagnosis software (DVD 85-00-2144/xx)
- Service computer (e.g. CF19 Hako order No. 03501860, english keyboard)
- Interface PN 03501750* (as Software-License) or 03502430** (as Software-License and USB to RS232 (COM) converter) – works only at the B115 R as a converter USB to RS232
- B90CL-serial-connect-cable (Diagnosis cabel) PN 03502110***
- Diagnosis plug PN 03006790

Connection schemes with the two different Interfaces see chapter 2.1.3

2.1.1 Connection with the Diagnosis-Computer

Please download the up to date diagnosis software (HakoDiagnose) as folder or as zip-file from Hako WEB-X Download Portal.

For information regarding the access to this download server, please ask Mrs. Maike Christiansen under e-mail: mchristiansen@hako.com

To install the diagnosis software on a service computer:

- 1) Delete the folder "C:\HakoDiagnose" and „C:\MDT“ from the Harddisk of your Service computer. Then delete the old desktop shortcuts.
- 2) Copy the folder "HakoDiagnose" to your Hard disk "C:\"
- 3) Open the folder "C:\HakoDiagnose\Runtime V1.XX.YYYY\" and run the programm "setup.exe"; Confirm all checkboxes

2.1.2 Flashing of the control unit

To flash the B115 R control unit:

- Install the control unit PN 01273950 complete in a machine. Activate the back up battery by removing the insulating strip between the button cell CR2032 and the battery holder on the back of the pcb (PN 01273590)
- Connect the Interface (*/**) to a free USB port of your service-computer.
- Connect the control unit to the service PC with the known devices (SIE-Interface - PN 03501750* (or PN 03502430**) at a USB port. The D-SUB9 connector of the B90CL-serialconnect-cable - PN 03502110*** is connected to the RS232 port of the computer, if the Interface * is used. In case the Interface ** is used, connect the DSUB9 connector of the Diagnosis cable with the D-Sub9 connector of the Interface **, that is marked with "RS232". The Molex 6-Pin connector is plugged into connector X3 of the machine control unit.
- Switch on the power of the machine.
- Run the Hako Diagnosis Software. Select the button "HAKO", then the button "Scrubmaster B115 R / Hakomatic B115 R". This will start the flashing tool for the Scrubmaster B115 R. The flash-tool looks for a (brand new) control unit.

2.1.2 Flashing of the control unit

- Follow the instructions, key in the Hako-serial and do not disconnect the cable and / or switch off the computer or the machine before the job is completed.
- The settings for options, battery type and parameter you can change by using the buttons on the operating panel with plugged diagnosis plug. Please follow the Service Booklet.
-
- SIE-Interface - PN 03501750 - at a USB port is required as a license dongle for the software
- ** SIE-Interface - PN 03502430 - at a USB port is required as a license dongle for the software and as a converter USB to RS232 (COM)
- *** B90CL-serial-connect-cable - PN 03502110- is the communication cable between the control unit PN 01273950 and the RS232 port of the computer. The communication connector on the control unit PN 01273950 is connector X3.

2.1.3 Connection schemes with different interfaces

Configuration (1) with Interface PN 03501750 *:

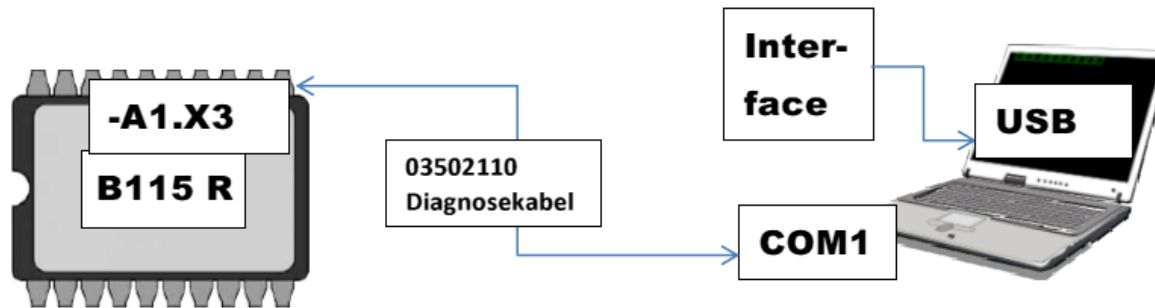

Configuration (2) with Interface PN 03502430 **:

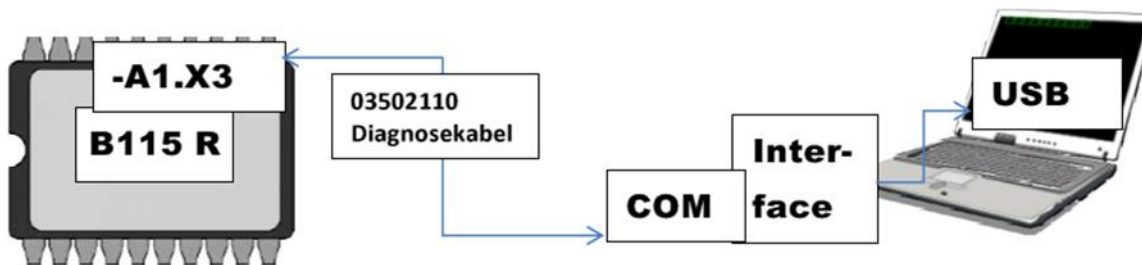

2.2 Short Description

The vehicle is controlled by means of the following electronics:

- Central electronics system (A1)
- Operating and indicator panel (A2)
- Drive control (A4)

The control electronics (A1) assumes all the control and monitoring tasks in the vehicle except for the driving functions.

No special diagnostic code appears in the display should a drive control error occur because the drive control is provided with a separate diagnostics display (blink code via the LED on the drive control) (see Chapter 9).

It is possible to switch between the buttons controlling scrubbing and vacuuming and the green Hakomatic button for combined cleaning as required so that the function selected at any moment is activated. On pressing the "Boost" button, the brush pressure is increased and the water quantity is set to its maximum level, as long as this button is depressed.

The hand-operated tool can only be used when the parking brake is applied and the seat contact switch is open.

2.2.1 Deactivating Vacuuming / Dirty Water Tank Full

Vacuuming is switched off manually by the operator using the corresponding button or automatically when the “Dirty water tank full” signal is received in order to protect the suction turbines.

Deactivation by the operator:

- Squeegee is raised
- Suction motor switches off after a delay (15 second)

Deactivation due to full tank:

- The “Dirty water tank full” switch opens as soon as the tank is full
- If the switch remains open longer than 3 seconds (splashing protection), the squeegee is raised and the suction motor is switched off after a delay (15 seconds).

2.2.2 Home Position of the Machine

After switching the machine on, all the components are set to their "home position" when the seat contact switch is actuated (closed).

The lifting elements are raised as long as they have not been switched off by the microswitch monitoring the top end position integrated in the lifting element.

The motors are switched off and the LED indicators in the cleaning component operating panel go out.

The lifting unit for the brush head has an integrated position detector controlled via a potentiometer.

When disassembled, the spindle of the lift element must not be turned, otherwise the positioning of the lift elements is disadjusted.

2.2.3 Seat Contact Switch (3.6.6.4.)

The seat contact switch is connected to the control electronics A1 at A1:X9.8+18. The control electronics (A1) reacts to the opening of the seat contact switch with a 2-second delay. This means: if the contact is opened for longer than 2 seconds during operation, the motors stop and the brush head and squeegee are raised.

If the switch is closed again within the 2 seconds, the machine continues to operate without any interruption.

If an attempt is made to switch the machine on without the seat contact switch being closed or the switch is open for longer than 2 seconds, all the machine's functions (driving and clean) are inhibited.

If the seat contact switch remains closed or opened for longer than 6 hours without an interruption, all the machine's functions are deactivated. The service code 3.6.6.4. appears in the operating hour counter. It is only possible to drive at this point. If the key switch is switched off and on again without the seat contact switch being opened or closed, the driving function is deactivated too.

2.2.3 Seat Contact Switch (3.6.6.4.)

To reactivate the machine functions after the “seat contact switch manipulation” was triggered, the control system needs to recognize a change in switch position (ON-OFF-ON or OFF-ON-OFF).

Seat contact closed means, the operator is on the seat;

Seat contact open means, no operator is on the seat.

When the seat contact switch is closed, the hour meter in the display is constant on, while it is blinking, when the switch is open.

The drive control is provided with its own diagnosis and self-test.

Therefore, the function of the drive control is inhibited when the machine is switched on if the drive potentiometer is not in its neutral position or is not detected as being in neutral.

The same occurs after the seat contact switch has been opened and is closed again.

Even when the seat contact switch is closed, the drive potentiometer must be in neutral, or rather: detected as being in neutral by the drive control.

If the drive control detects the drive potentiometer as not being in neutral, it initiates flashing signals (LED) on the drive control.

2.2.4 Introduction to Programming

The Hakomatic B115R can be configured by means of the software and adapted to various options. The software is also used to adapt the machine to the various hardware (machine type, disk brush head or cylindrical brush head, batteries - TSG).

The modification of parameters not described in this manual could lead to machine malfunction. Therefore, the utmost care must be taken with all alterations to the configuration.

Introduction to the Configuration Menu

Proceed as follows to access the Configuration menu:

- First of all, plug the diagnostics connector 0300 6790 on connector A1.X3 of the control electronics (Fig. 2/2). This is necessary to be able to change and save parameters.

2.2.4 Introduction to Programming

Press and hold Buttons 1 and 2 simultaneously (Fig. 2.3) and switch on the key switch. The following display appears in the operating hour counter after approx. 3 seconds:

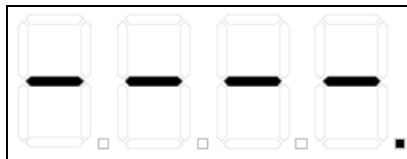

Fig. 2.1

- The start screen of the Configuration menu is now open.
Press Button 2 to access Chapter 0 of the Configuration menu.

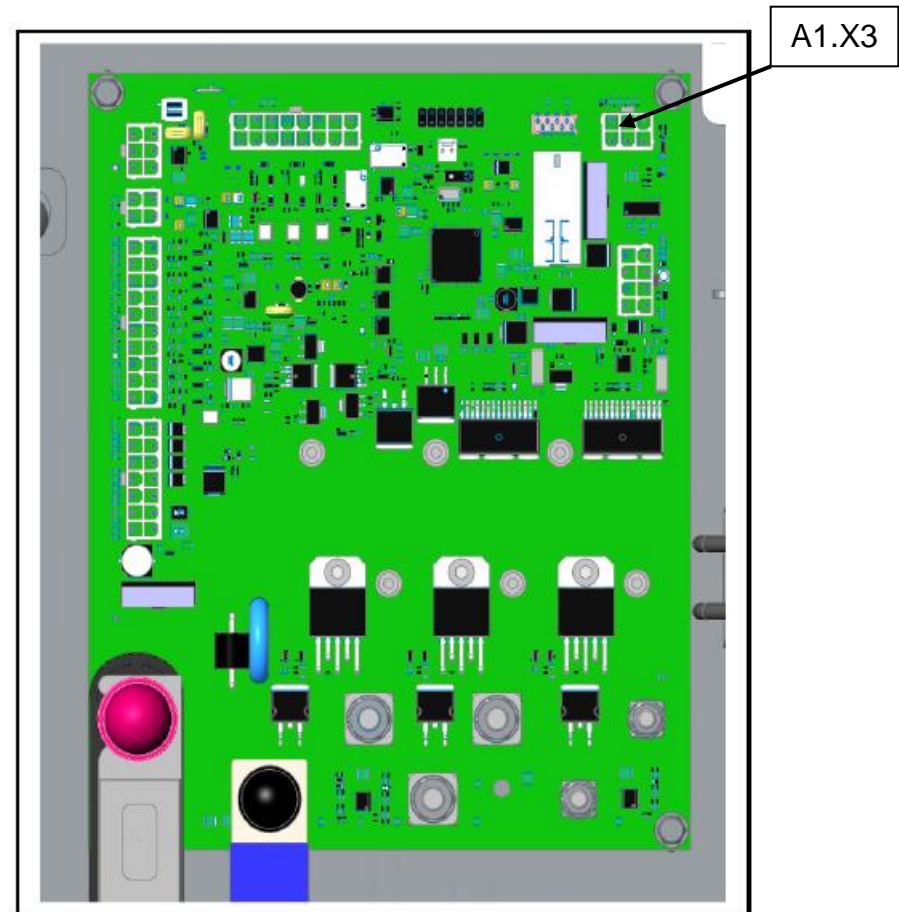

Fig. 2.2

2.2.4 Introduction to Programming

You can navigate through the Configuration menu using the three 3 buttons indicated on the operating panel. Button 1 is the "Water on/off " button; Button 2 the "Water +/-" button; Button 3 the "Silent Mode" button (Fig. 2/3).

The Configuration menu is represented by 3 digits (Fig. 2/4) which describe the individual levels. The left-hand digit indicates the chapter, the middle digit the configuration and right-hand digit the content. The digit which is to the left of the flashing point is the one which is currently active (Chapter, Configuration or Content).

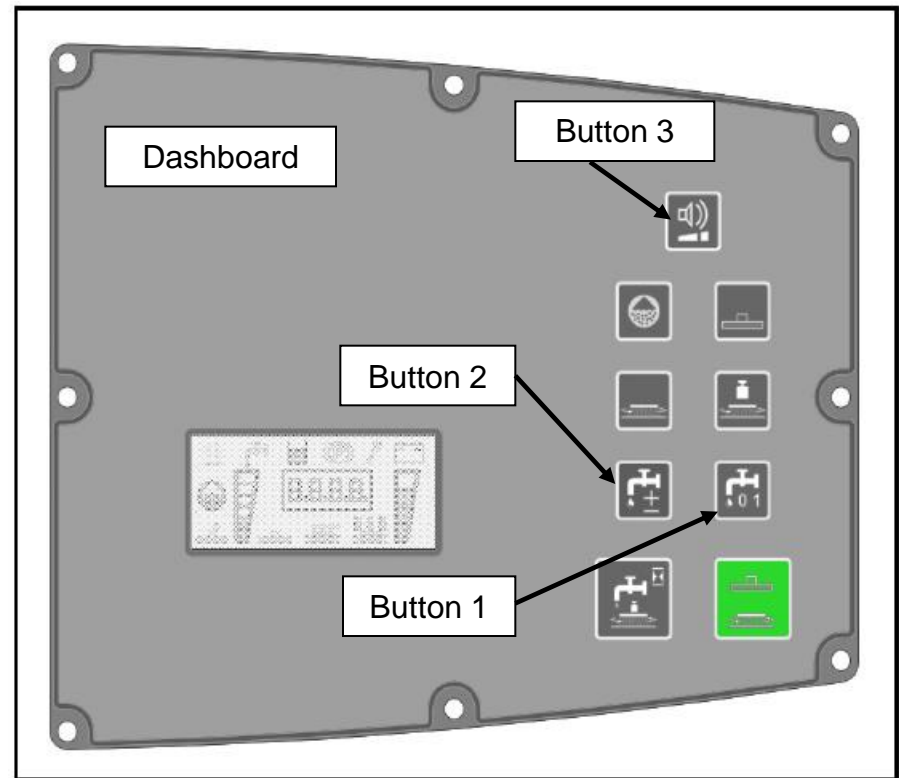

Fig. 2.3

2.2.4 Introduction to Programming

Press Button 1 to change the active level:

Chapter -> Configuration -> Content -> Chapter

Press Button 2 to increase the value in the active level.

After reaching the highest value, pressing again calls in the lowest value.

Press and hold Button 3 for min. 3 seconds to save the Content setting selected, as long as the diagnostics connector is plugged into A1.X3.

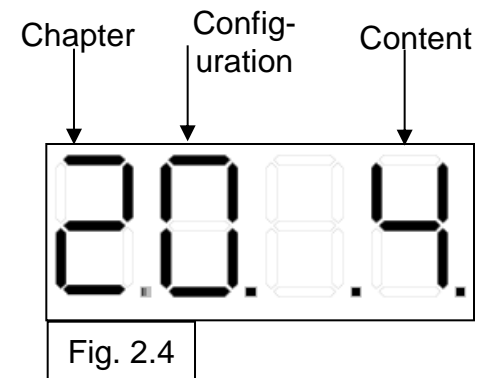

In the parameter tables, "d" always signifies default setting.

2.2.5 Reset Last Error Which Occurred in the Start Screen

Access the programming level as described in Chapter 2.2.4. Fig. 2.1 appears. The diagnostics connector must be connected to A1.X3.

Press Button 2 six times, the last error which occurred is indicated in the display. e.g.

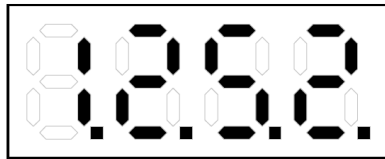

Press and hold Button 3 for approx. 3 seconds until "0.0.0.0." appears in the display. Switch the machine off using the key switch and disconnect the diagnostics connector from A1.X3.

3 Technical Data

Technical data:	Hakomatic	B 115 R TB 650	B 115 R WB 700	B 115 R TB 750	B 115 R WB 850	B 115 R TB 900
Working width	cm	65	70	75	85	90
Effective suction width	cm	86	95	95	110	110
Area performance up to approx.	m ² /h	4.200	4.500	4.800	5.500	5.800
Working speed up to	km/h	6,5	6,5	6,5	6,5	6,5
Voltage	Volt	24	24	24	24	24
Protection class (VDE 0700)		III	III	III	III	III
Air volume, vacuum	m ³ /h	118	118	118	118	118
Pressure, vacuum	mbar	170	170	170	170	170
Drive motor capacity	W	800	800	800	800	800
Brush motor capacity	W	870	2 x 870	870	2 x 870	2 x 960
Vacuum motor capacity	W	550	550	550	550	550
Number of brushes	Pieces	2	2	2	2	2
Brush diameter	cm	33	15	38	15	46
Brush revolutions	rpm	210	850	210	850	210
Brush pressure up to	kg	56	33	60	35	70
Clean / dirty water tank	Liter	116/116	116/116	116/116	116/116	116/116
Dirt hopper, gross	Liter		5		5	
Climbing ability ready for operation	%	10	10	10	10	10
Length with squeegee	cm	166	166	166	168	168
Width without/with squeegee	cm	80/86	80/95	80/95	95/110	95/110
Height	cm	144	144	144	144	144
Turning circle in aisle	cm	170	170	170	175	175
Weight, empty, without batteries	kg	330	340	340	347	347
Total weight ready for operation	kg	706	716	716	727	727
Specific wheel pressure up to	N/mm ²	0,6	0,6	0,6	0,6	0,6

3 Technical Data

	Unit	TB 650	TB 750	TB 900	WZB 700	WZB 850
Tank volume						
Clean water tank tank	Liters	116	116	116	116	116
Waste water tank	Liters	116	116	116	116	116
Brush head						
No. of brushes	Pieces	2	2	2	2	2
Brush speed	rpm	210	200	215	850	850
Suction						
Air flow rate	m ³ /h	110	110	118	110	118
Vacuum	mbar	170	170	170	170	170
Electrical installation						
Nominal voltage	V	24	24	24	24	24
Nominal power (max.) (P1)	W	3260	3260	3260	3100	3100
Power consumption, drive motor (P1 / S2-120 min)	W	816	816	816	816	816
Power consumption, aspirating engine (P1)	W	528	528	528	528	528
Power consumption, brush motor (P1)	W	960	960	960	876	876
Power consumption, water pump (P1)	W	100	100	100	100	100
Protection class		III	III	III	III	III
Type of protection		IPX3	IPX3	IPX3	IPX3	IPX3

3 Technical Data

<p>Noise emission value</p> <p>The sound power level (LwAd) measured according to EN 60335-2-72 under normal under working conditions is:</p> <p>The sound pressure level (LpA) measured according to DIN EN 60335-2-72 (at the driver's ear) under normal working conditions is:</p> <p>Measurement inaccuracy (KpA):</p>	<p>dB (A)</p> <p>dB (A)</p> <p>dB (A)</p>	<p>85</p> <p>66</p> <p>2</p>
<p>Vibration</p> <p>The weighted effective value of acceleration, measured in accordance with DIN EN ISO 5349, to which the upper parts of the body (hand-arm) are exposed under normal working conditions:</p>	<p>m/s²</p>	<p>< 2.5</p>

4. Maintenance Intervals

In a modular structure, the Hako System Maintenance determines the specific technical works to be executed and equally fixes the period between two maintenance cycles.

For each of the maintenances, the replaceable parts are determined as well.

Find further details described in the specific chapters.

Hako System Maintenance K:

To be performed by the customer in accordance with the maintenance and care instructions contained in the operating instructions (daily or weekly). The driver/operator will be instructed upon delivery of the machine.

Hako System Maintenance I: (every 250 hours of operation)

To be performed by qualified personnel of authorised Hako Service Centre in accordance with the machine-specific system maintenance including spare part kit.

Hako System Maintenance II: (every 500 hours of operation)

To be performed by qualified personnel of authorised Hako Service Centre in accordance with the machine-specific system maintenance including spare part kit.

Hako System Maintenance S: (every 1000 hours of operation, safety check)

To be performed by qualified personnel of authorised Hako Service Centre in accordance with the machine-specific system maintenance including spare part kit.

Execution of all safety-relevant inspections according to UVV-BGV-TÜV-VDE as prescribed by law.

4.1 Hako System Maintenance K

The daily and weekly maintenance intervals must be performed by the customer/operator.

Activity	Interval	
	Daily	Weekly
Empty and clean the waste water tank	o	
Check the lid seal of the waste water tank; clean, if necessary	o	
Check the battery charge; recharge, if necessary	o	
Check the clean water filter; clean or change as necessary	o	
Fill the clean water tank and dose the chemicals	o	
Check the sealing strips on the squeegee; turn or change as necessary	o	
Check the deflector rubber of the side deflector, change as necessary	o	
Check the scrubbing quality of the brush head; clean the brushes, pad and pad holder if necessary		o
Check the suction power of the squeegee; clean or change the sealing strips as necessary		o
Check the suction hose between the squeegee and waste water tank is fitted firmly and for signs of damage		o
Check the brushes and water retaining ring are fitted firmly and for signs of wear, change as necessary		o
Test drive and function test		o

4.2 Hako System Maintenance I

The following maintenance work must be performed by an authorised Hako Service workshop.

Activity	Interval
	Every 250 operating hours
Check the battery acid level and acid density; top up distilled water (PzS version), if necessary	o
Check the charger (ventilation grid and air channel)	o
Grease the steering pinion and gear rim	o
Check the functionality of the brake and parking brake lock	o
Check the brush head; change worn parts as necessary	o
Check the clean water system; change worn parts as necessary	o
Check the waste water and vacuum system; change worn parts as necessary	o
Clean the brush motor ventilation grid of fluff and dirt	o
Check the squeegee connection and rollers, adjust as necessary	o
Check the front safety bar with deflection roller	o
Check the wheel mounting bolts; retighten, if necessary (42 Nm)	o
Check the electrical system; change worn parts as necessary	o
Check the visual appearance of the vehicle (color, corrosion and labels)	o
Test drive and function test	o

4.3 Hako System Maintenance II

The following maintenance work must be performed by an authorised Hako Service workshop.

Activity	Interval
	Every 500 operating hours
All maintenance work in accordance with Hako system maintenance I	o
Read out the error memory and evaluate the error messages	o
Check the brake disk and brake blocks; change, if necessary	o
Check the electric power (hydraulic motor, brush motor and suction turbine)	o
Change the backup battery and set the real-time clock	o
Check the visual appearance of the vehicle (color, corrosion and labels)	o
Test drive and function test	o

4.4 Hako System Maintenance S (Safety Check)

The following maintenance work must be performed by an authorised Hako Service workshop.

Activity	Interval
	Every 1000 operating hours
All maintenance work in accordance with Hako system maintenance II	o
Clean carbon dust from the drive motor and check the carbon brushes move easily and for signs of wear; change the carbon brushes, if necessary (Only DC motor)	o
Clean carbon dust from the brush motors and check the carbon brushes move easily and for signs of wear; change the carbon brushes, if necessary	o
Test drive and function test	o

5. Cleaning Programs (FPV)

The cleaning programs define the behavior of the water supply to the brushes, the brush motors in respect of the position of the drive direction switch, the drive potentiometer (forwards, neutral, reverse) and the squeegee.

The drive direction switch S07 and drive potentiometer switch S08 provide a 24 V signal for forward drive at input A01.X10:4 and for reversing at input A01.X10:5. If no voltage signal is applied, the cleaning units are not activated.

The reaction of the cleaning functions is described in Table 5.1.

To select a cleaning program, access the programming level as described in Chapter 2.2.4. The cleaning programs available are listed in Table 5.2.

To save any program changes, press Button 3 for min. 3 seconds. Then disconnect the diagnostics connector from A1.

5. Cleaning Programs (FPV)

Function	Contents								
	1	2	3	4	5	6	7	8	9
Brush off when drive control is in neutral	Yes	Yes	Yes	Yes	Yes	Yes	Yes	Yes	Yes
Brush off when drive control is in reverse	No	No	Yes	No	No	Yes	No	Yes	No
Lift brush when drive control is in neutral	No	No	No	Yes	Yes	Yes	Yes	No	No
Lift brush when drive control is in reverse	No	No	No	No	No	Yes	No	No	No
Water off when drive control is in neutral	Yes	Yes	Yes	Yes	Yes	Yes	Yes	Yes	Yes
Water off when drive control is in reverse	No	Yes	Yes	No	Yes	Yes	Yes	Yes	No
Lift squeegee when drive control is in neutral	No	No	No	No	No	No	No	No	No
Lift squeegee when drive control is in reverse	No	Yes	No	Yes	No	No	Yes	Yes	Yes

Chart 5.1

5. Cleaning Programs (FPV)

Chapter	Configuration	Contents	Description	B115 / PB650	B115 / PB750 / CB700	B115 / PB900 / CB850
				99-7090-51	99-7090-11 / 21 / 35 / 41	99-7090-81 / 91
3	0		FPV Set			
3	0	1	Refer to FPV table	x	x	x
3	0	2	Refer to FPV table	d	d	d
3	0	3	Refer to FPV table	x	x	x
3	0	4	Refer to FPV table	x	x	x
3	0	5	Refer to FPV table	x	x	x
3	0	6	Refer to FPV table	x	x	x
3	0	7	Refer to FPV table	x	x	x
3	0	8	Refer to FPV table	x	x	x
3	0	9	Refer to FPV table	x	x	x

Chart 5.2

6. Machine Settings

6.1 Basic Settings

6.1.1 Machine Type

There are various model types, equipment installed and working widths regarding the machines in the Hakomatic B115R series. These types can be set in the Configuration menu.

To check and change the machine type setting, access programming level as described in Chapter 2.2.4. The parameters setting possible are stipulated in Chart 6.1.

6. Machine Settings

6.1 Basic Settings

6.1.1 Machine Type

Chapter	Configuration	Contents	Description	B115 / PB650	B115 / PB750 / CB700	B115 / PB900 / CB850
				99-7090-51	99-7090-11 / 21 / 35 / 41	99-7090-81 / 91
0	1		Machine Model			
0	1	3	Hakomatic B115 / 650 (99.7090.51)	x		
0	1	5	Hakomatic B115 / 750 / 700 (99.7090.11/.21/.35/.41)		x	
0	1	7	Hakomatic B115 / 900 / 850 (99.7090.81/.91)			x

Chart 6.1

6. Machine Settings

6.1.2 Cleaning Units

Different brush units can be used with the Hakomatic B115R.

Three disk brush units are available with working widths of 65 cm, 75 cm and 90 cm.

Two cylindrical brush units with working widths of 70 cm and 85 cm are also available.

This setting is necessary to ensure correct function of the overload limits and the water quantities.

To check and change the machine type setting, access programming level as described in Chapter 2.2.4. The parameters setting possible are stipulated in Chart 6.2.

6. Machine Settings

6.1.2 Cleaning Units

Chapter	Configuration	Contents	Description	B115 / PB650	B115 / PB750 / CB700	B115 / PB900 / CB850
				99-7090-51	99-7090-11 / 21 / 35 / 41	99-7090-81 / 91
0	2		Cleaning Units			
0	2	1	Disk brush 650 mm	d		
0	2	2	Disk brush 750 mm		d	
0	2	4	Disk brush 900 mm			d
0	2	6	Cylindrical brush 700 mm		x	
0	2	7	Cylindrical brush 850 mm			x

Chart 6.2

6. Machine Settings

6.1.3 Battery Setting (TSG - total discharge signal transducer)

In order to achieve the optimum operating time for the machine with the batteries installed and optimum service life of the batteries, it is essential to set the battery monitor, referred to as TSG, to the correct discharge curve.

Batteries of different construction are available which differ according to their discharge parameters.

To check and change the machine type setting, access programming level as described in Chapter 2.2.4. The parameters setting possible are stipulated in Chart 6.3.

6. Machine Settings

6.1.3 Battery Setting (TSG - total discharge signal transducer)

GiS and GiV are flat plate batteries,

PzS and PzV are tube plate batteries

GiV and PzV are sealed, absolutely maintenance-free gel batteries



GiS and PzS are sealed, low-maintenance batteries with liquid electrolyte. AGM batteries are wrapping electrodes with fiberglass separators. In the case of block batteries, the following designations are used:

GiS = FF

GiV = GF-Y; GF-V

PzS = FT

Trough batteries of the following type are available:

EPzS and EPzV

6. Machine Settings

6.1.3 Battery Setting (TSG - total discharge signal transducer)

Chapter	Configuration	Contents	Description	B115 / PB650	B115 / PB750 / CB700	B115 / PB900 / CB850
				99-7090-51	99-7090-11 / 21 / 35 / 41	99-7090-81 / 91
0	3		Battery Setting			
0	3	0	Crown without offset	x	x	x
0	3	1	Crown with offset	x	x	x
0	3	2	GIS, "foreign"	x	x	x
0	3	3	GIS	x	x	x
0	3	4	PzS, "foreign"	x	x	x
0	3	5	PzS	x	x	x
0	3	6	GiV	d	d	d
0	3	7	PzV	x	x	x
0	3	8	Hoppeke AGM with offset	x	x	x

6. Machine Settings

6.1.4 Charger

This menu option is used to define whether the machine is equipped with an integrated charger. This adjustment is necessary so that the TSG can operate correctly.

To check and change the machine type setting, access programming level as described in Chapter 2.2.4. The parameters setting possible are stipulated in Chart 6.4.

6. Machine Settings

6.1.4 Charger

Chapter	Configuration	Contents	Description	B115 / PB650	B115 / PB750 / CB700	B115 / PB900 / CB850
				99-7090-51	99-7090-11 / 21 / 35 / 41	99-7090-81 / 91
0	4		Chargers			
0	4	0	Charger not available	d	x	x
0	4	1	Charger available	x	d	d

Chart 6.4

6. Machine Settings

6.2 Settings On Customer Request

The programmable program versions can be used to complete various settings on the machines.

E.g. it is possible to program whether the last error which occurred on the machine should be displayed or not when the machine is switched on again.

To check and change the PPV setting, access programming level as described in Chapter 2.2.4. The parameters setting possible are stipulated in the following chart.

6. Machine Settings

6.2 Settings On Customer Request

Chapter	Configuration	Contents	Description	B115 / PB650	B115 / PB750 / CB700	B115 / PB900 / CB850
				99-7090-51	99-7090-11 / 21 / 35 / 41	99-7090-81 / 91
2	0		"Last error" indicator after switching on the machine			
2	0	0	Deactivate	x	x	x
2	0	1	Activate	d	d	d
2	1		Water level when switching on scrubbing			
2	1	0	Last setting	d	d	d
2	1	1	Preset level (4)	x	x	x

Chart 6.5/1

6. Machine Settings

6.2 Settings On Customer Request

Chapter	Configuration	Contents	Description	B115 / PB650	B115 / PB750 / CB700	B115 / PB900 / CB850
				99-7090-51	99-7090-11 / 21 / 35 / 41	99-7090-81 / 91
2	2		Water level when switching on scrubbing and vacuuming			
2	2	0	Last setting	d	d	d
2	2	1	Preset level	x	x	x
2	3		Water level when switching on TOOL (menu option only appears when TOOL option is activated!)			
2	3	0	Last setting	d	d	d
2	3	1	Preset level (4)	x	x	x

Chart 6.5/2

6. Machine Settings

6.2 Settings On Customer Request

Chapter	Configuration	Contents	Description	B115 / PB650	B115 / PB750 / CB700	B115 / PB900 / CB850
				99-7090-51	99-7090-11 / 21 / 35 / 41	99-7090-81 / 91
2	6		Water Setting			
2	6	0	From last level to first level (in circuit)	d	d	d
2	6	1	Change direction on reaching max./min. level (ping-pong)	x	x	x
2	7		Silence Mode Setting (menu option only appears when Silence Mode option is activated!)			
2	7	0	Is not saved	x	x	x
2	7	1	Is saved	d	d	d

6. Machine Settings

6.2 Settings On Customer Request

Chapter	Configuration	Contents	Description	B115 / PB650	B115 / PB750 / CB700	B115 / PB900 / CB850
				99-7090-51	99-7090-11 / 21 / 35 / 41	99-7090-81 / 91
2	8		Acoustic Alarm Tone Interval (menu option only appears when the Acoustic Alarm option is activated!)			
2	8	0	Standard	d	d	d
2	8	1	Alternative	x	x	x

Chart 6.5/4

7. Mechanical Components

7.1 Squeegee

- 1 Squeegee
- 2 Star-shaped knob
- 3 Screw for angle adjustment
- 4 Suction hose
- 5 Fastening device
- 6 Washers for height adjustment

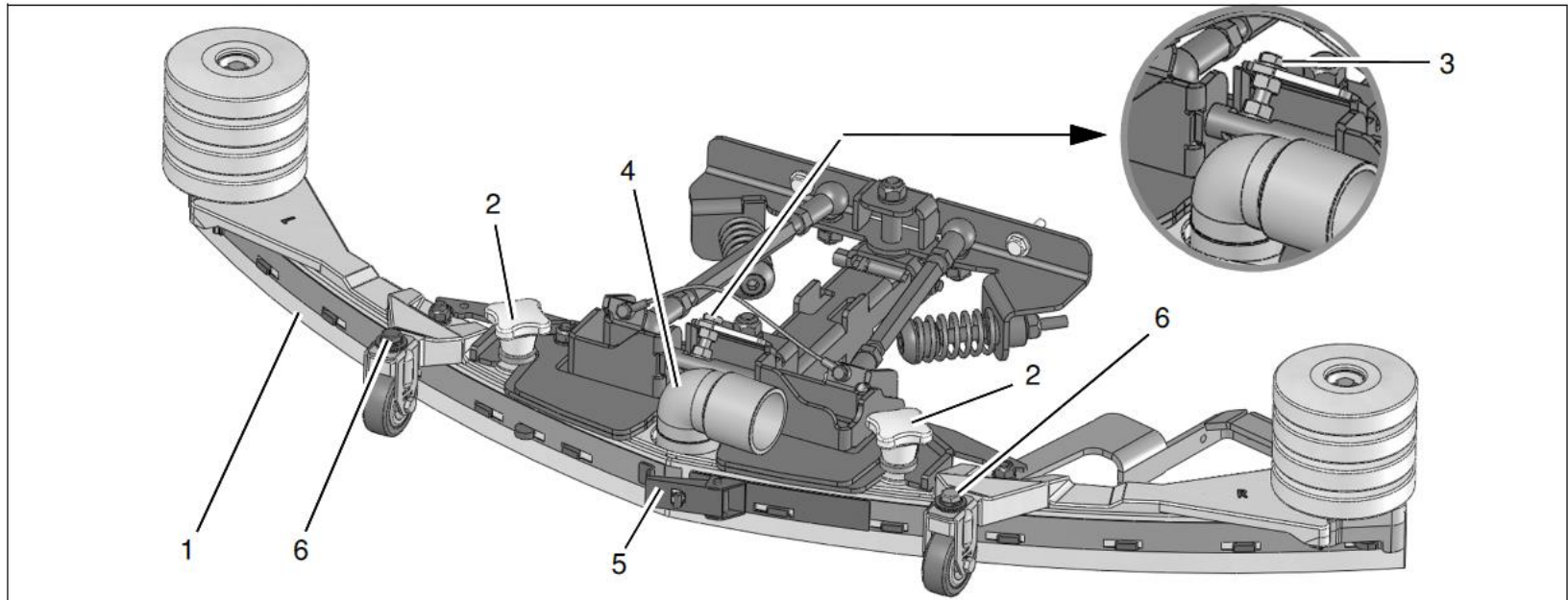

Fig. 7.1

7. Mechanical Components

7.1 Squeegee

Adjustment / Angular adjustment of the sealing strips

The angle adjustment is the decisive factor in ensuring the squeegee's sealing strips lie evenly on the floor.

1. Park the machine on a level surface and lower the squeegee.
2. Loosen the conternut on the screw (Fig. 7.1/3) and use the conternut to adjust the squeegee so that the ends of the sealing strips just make contact with the floor.

Fig. A (Fig. 7.2)

Turn the conternut counterclockwise: Distance from sealing strip to floor is reduced in the middle.

Fig. B (Fig. 7.2)

Turn the conternut clockwise: Distance from sealing strip to floor is increased in the middle.

3. Switch the vehicle on and check the suction pattern. While driving, the sealing strips must make a full, even contact with the floor (in the center and at both ends).
4. Tighten the conternut of the adjusting bolt at 7 Nm.

7. Mechanical Components

7.1 Squeegee

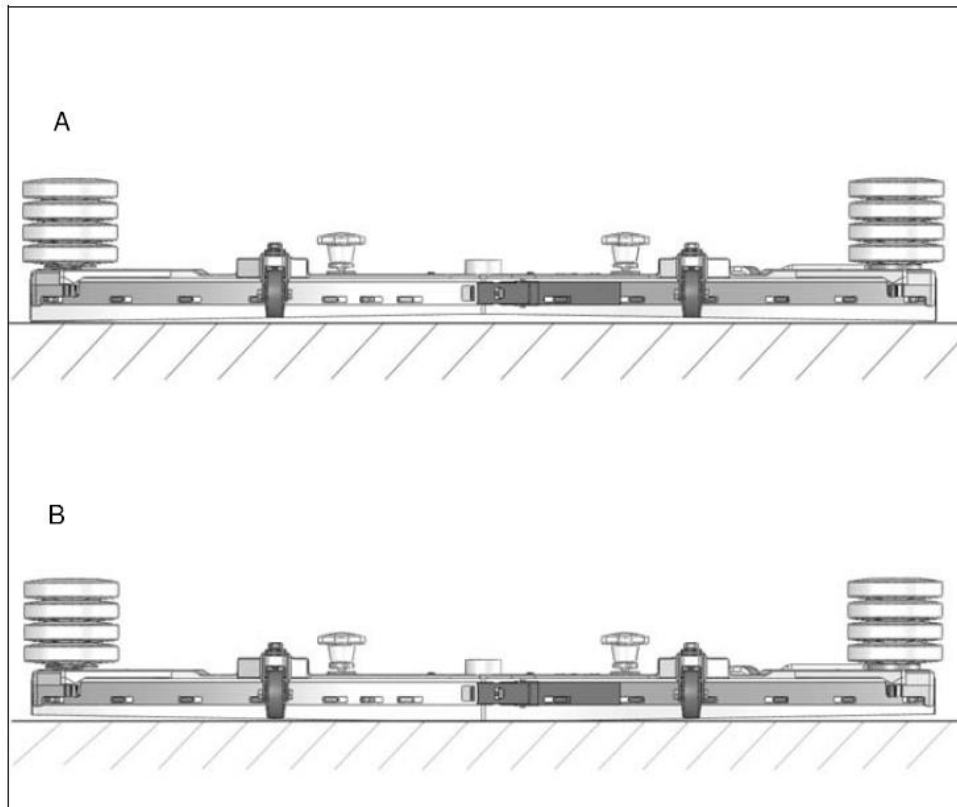

Fig. 7.2

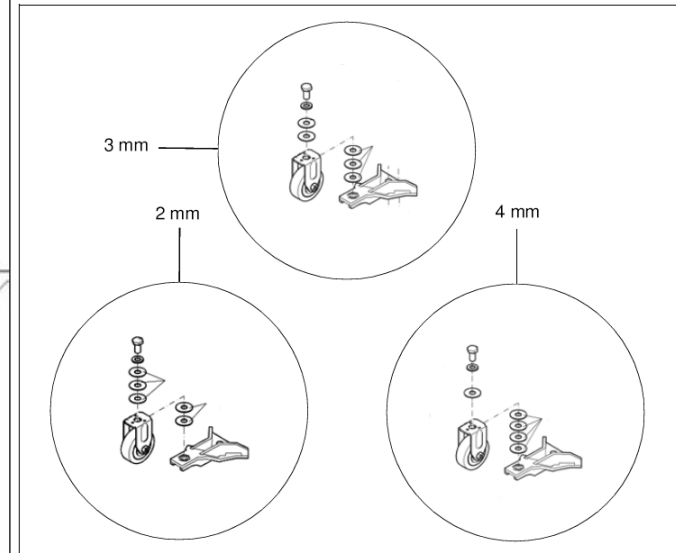

Fig. 7.3

7. Mechanical Components

7.1 Squeegee

Height adjustment

The height adjustment is set to 3 mm at the factory. If, despite an optimum angle adjustment, streaks are produced, the distance between the rollers and floor must be adjusted by altering the number of washers (Fig. 7.1/6 / Fig. 7.3) on the holder.

In the case of very smooth floors, e.g. coated screed, PVC, linoleum etc., the number of washers = 2.

This corresponds to a distance of approx. 2 mm to the floor.

In the case of very uneven floors, e.g. badly laid tiles (puddles form), the number of washers = 4.

This corresponds to a distance of approx. 4 mm to the floor.

7. Mechanical Components

7.1 Squeegee

Squeegee connection

The drawing (Fig 7.4) specifies the dimensions for adjusting of the suspension springs (60 mm) and the threaded rods for adjusting the parallel alignment (151 mm) of the squeegee connection.

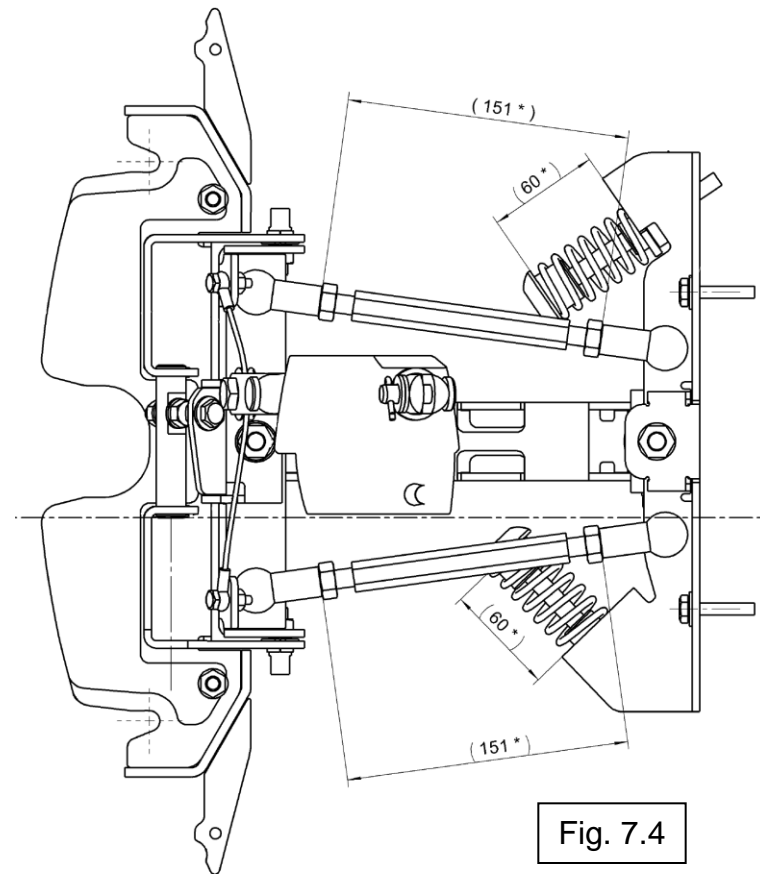

Fig. 7.4

7. Mechanical Components

7.2 Disk Brush Head

Disk brush heads in 3 different working widths are available for the Hakomatic B115R; 65 cm, 75 cm and 90 cm.

The two brushes are each driven by a separate motor.

7.3 Cylindrical Brush Head

Cylindrical brush heads are available for the Hakomatic B115R in 2 different working width; 70cm and 85cm.

7. Mechanical Components

7.3.1 Adjusting the cylindrical brush head

Adjusting the cylindrical brush head

Produce a distance of 30 mm between the cylindrical brush head and ground by inserting the spacer blocks from the adjustment kit PN 01078870 at the left and right on the brush head (Fig. 7.6).

Adjust the distance by turning the adjusting bolt (Fig. 7.9/1) and check guide II (Fig. 7.7) with adjusting plate I on both sides.

Set adjusting plate I between guide II and washer III flat on the slide stone. The adjustment is ideal when the middle edge of the adjusting plate is flush to the top edge of the guide.

If necessary, correct the adjustment so that the top edge of the guide is not higher than the + and not lower than the - edge of the adjusting plate on both sides.

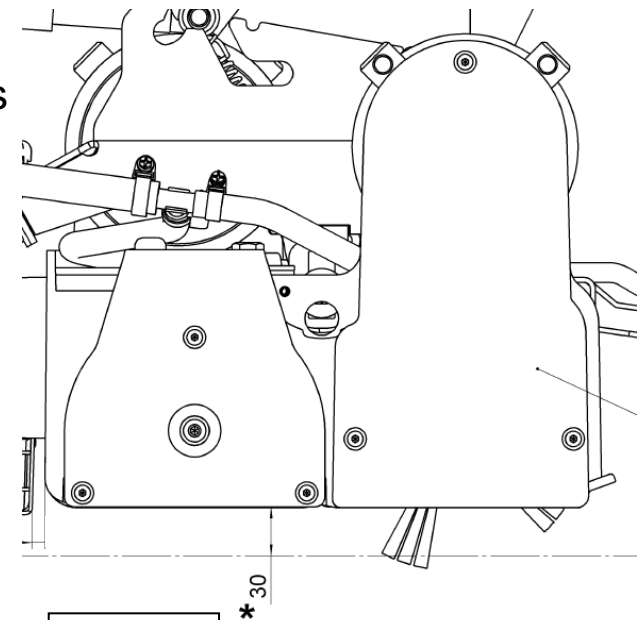

Fig. 7.6

7. Mechanical Components

7.3.1 Cylindrical Brush Head

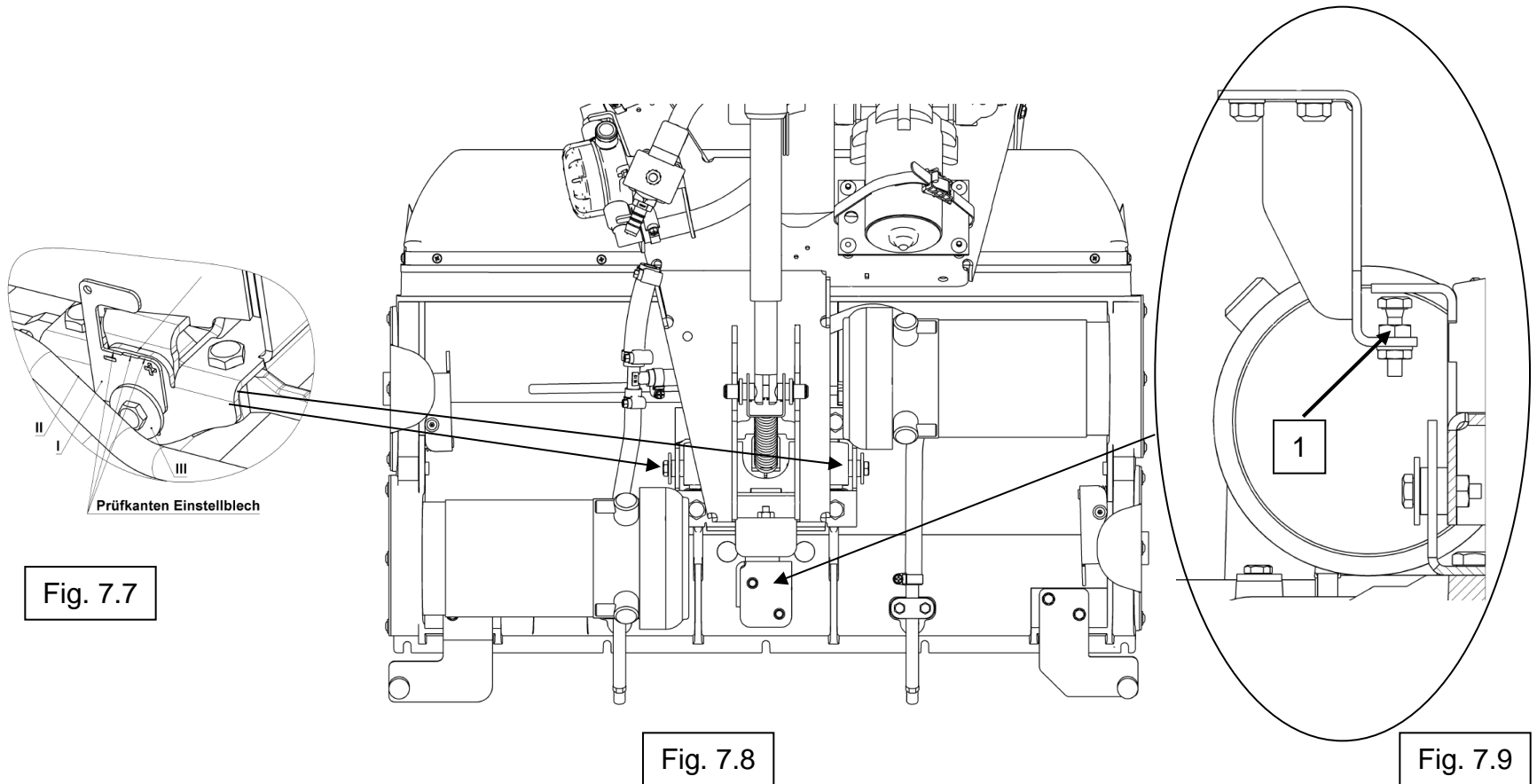

Fig. 7.7

Fig. 7.8

Fig. 7.9

7. Mechanical Components

7.4 Brush Head Lifting Unit

1 EM Lifting Attachment

When delivered, the lifting unit (Fig. 1/1) is extended 350 mm.

The cable ties (Fig. 1/2) serve as anti-twist devices for the piston rods!



Important assembly information!

The piston rod must not turn throughout the entire assembly.

The lifting unit may only be moved when installed.

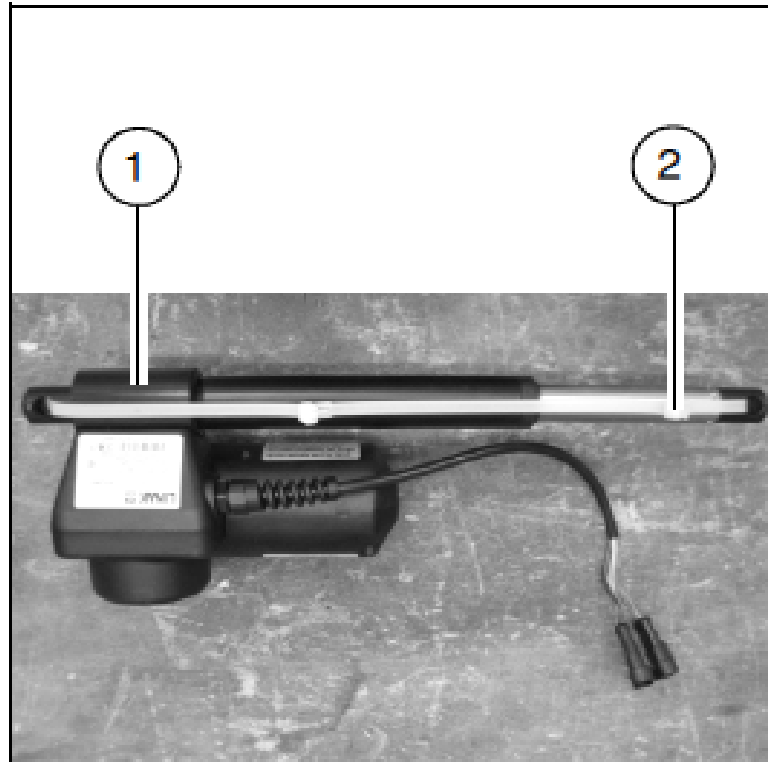

Fig.1

7. Mechanical Components

7.4 Brush Head Lifting Unit

1.1 Assembling the disk brush lifting unit

1. Lower the brush head by actuating the Cleaning button (operator must be seated on the seat in this case).
2. Switch the vehicle off using the key switch and disconnect the battery plug.
3. Disassemble the right-hand side deflector (viewing to the front).
4. Disconnect the cable contacts to the lifting unit.
5. Disassemble the cotter bolt (Fig. 2/1) from the brush head.
6. Disassemble the mounting support from the chassis and remove the lifting unit.
7. Release the anti-twist device from the new lifting unit.
8. Mount the lifting unit on the chassis and fix it in place.
9. Mount the brush head and fix it in place.
10. Connect the electrical connections.
11. Fix the cable to the rocker arm with the cable ties (the cable must not be crushed or be under strain when the brush head moves).

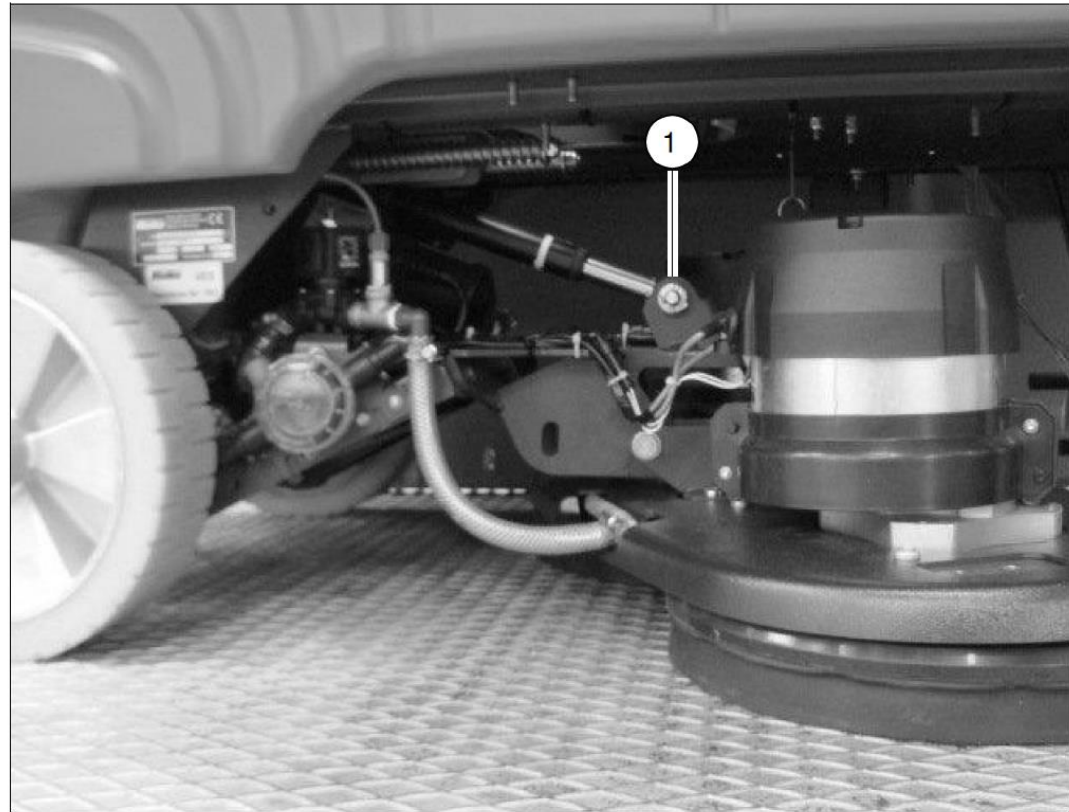

Fig.2

7. Mechanical Components

7.4 Brush Head Lifting Unit

1.2 Assembling the cylindrical brush lifting unit

1. Lower the brush head by actuating the Cleaning button (operator must be seated on the seat in this case).
2. Switch the vehicle off using the key switch and disconnect the battery plug.
3. Disconnect the cable contacts to the lifting unit.
4. Disassemble the front cotter bolt (Fig. 3/1) and insert the buckle with tension spring in the transport safety device.
5. Disassemble the mounting support from the chassis and remove the lifting unit.
6. Release the anti-twist device from the new lifting unit.
7. Mount the lifting unit on the chassis and fix it in place.
8. Assemble the buckle with tension spring and fix in place.
9. Connect the electrical connections.
10. Fix the cable to the rocker arm with the cable ties (the cable must not be crushed or be under strain when the brush head moves).

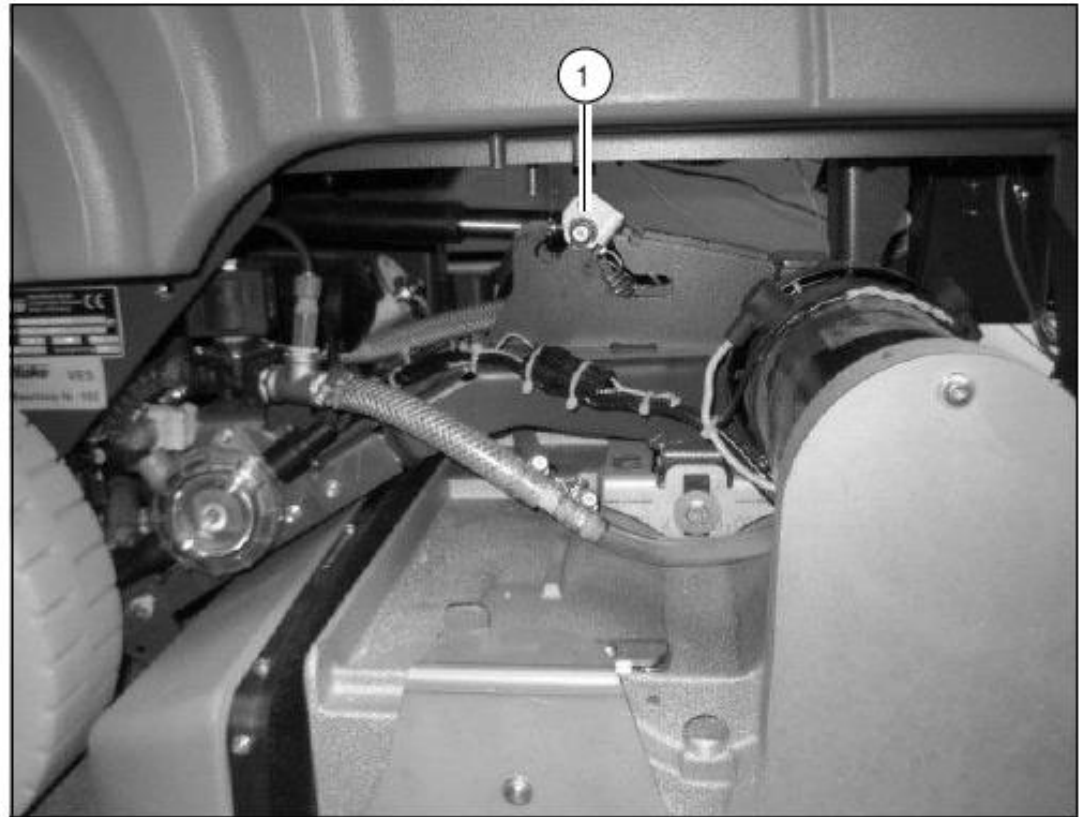

Fig.3

7. Mechanical Components

7.4 Brush Head Lifting Unit

7.4.1 Potentiometer in the Brush Head Lifting Unit

The potentiometer of the lifting element is powered by a 2.5 V reference voltage at A1.X19:1. Reference point for this voltage is A1.X19:3. Depending on the position of the potentiometer, the voltage at A1.X19:2 is between 0 and 2.5V.

Measuring point :

A1.X19:1 – A1.X19:3	2.5V Reference Voltage
A1.X19:2 – A1.X19:3	0..2.5V 0...2.5V depending on the position of the lifting element

Possible faults :

A1.X19:1- A1.X19:3 less than 2.5V or 0V

Short circuit in the wiring or in the potentiometer. 0V indicates a a short circuit to ground. Voltage less than 2.5V indicates an overload of output A1.X19:1.

A1.X19:2 – A1.X19:3: permanent 0V

Interruption in the wire to A1.X19:1 or A1.X19:2, faulty lifting element

A1X19:2 – A1.X19:3: permanent 2.5V

Interruption in the wire to A1.X19:3, faulty lifting element

8. Water Pump

To control the function of the water pump, the voltage for the individual levels can be disconnected at the central electronics unit (A1.X11:4+11). The following results are achieved when measuring with a True RMS measuring instrument and water in the tank but with the suction turbines switched off:

	<u>Disk brush</u>	<u>Cylindrical brush</u>
Level 1:	Approx. 3.5 V	Approx. 4.7 V
Level 2:	Approx. 4.2 V	Approx. 5.2 V
Level 3:	Approx. 5.1 V	Approx. 5.8 V
Level 4:	Approx. 7.6 V	Approx. 7.1 V
Level 5:	Approx. 9.8 V	Approx. 9.2 V
Level 6:	Approx. 15.2 V	Approx. 10.2 V

However, the measured values determined in the machines could deviate from the values achieved in practice. A more reliable method for controlling the water pump is to measure the water quantities actually fed.

8.1 Water Quantities

Measuring the water quantities provides a good, reliable method with which to check the function of the water pump. Let the pump run and measure the volume of water fed per minute (l/min.). The data regarding the water quantities is specified as follows in the operating manual:

Stage	1	2	3	4	5	6
Plate-brush	1,0	1,6	2,0	2,4	3,6	5,2
Cylindrical-brush	1,5	1,6	1,8	2,3	2,9	3,1

Water amount in l/min

If power is applied to the pump but the water quantity does not correspond to the information, check whether the hoses are clogged or kinked, that the solenoid valve is open fully and the membranes of the valve plate in the pump are in order. The solenoid valve is connected to -A1.X11:3 + 10.

8.2 Water Pump Standstill Recognition

If the pump does not supply water to the brushes due to clogging of the hoses, the so-called standstill recognition is activated.

Automatic standstill recognition for water pump:

The electronic module allows protection of the water pump if the pump does not deliver correctly. This means if the pump takes in water from the tank and cannot deliver it to the brushes, a pressure builds at the pump. Without being protected by the electronic module the pump would deliver against this pressure and could be damaged.

The electronic module detects the blocked delivery and automatically switches the pump off for 2 seconds.

After this delay, the pump is briefly switched on again and it is simultaneously measured whether delivery of water to the brushes is free or blocked.

If delivery is as required, the pump remains ON in the selected stage. If the pressure still exists, the pump is switched off again for 2 seconds. This procedure is repeated until the error is remedied.

9 Drive Control Units

The drive control is provided with its own diagnosis and self-test.

Therefore, the function of the drive control is inhibited when the machine is switched on if the drive potentiometer is not in its neutral position or is not detected as being in neutral.

The same occurs after the seat contact switch has been opened and is closed again.

Even when the seat contact switch is closed, the drive potentiometer must be in neutral, or rather: detected as being in neutral by the drive control.

If the drive control detects the drive potentiometer as not being in neutral, it initiates flashing signals (LED) on the drive control.

9 Drive Control Units

9.1 ATECH / ZAPI – DC Motor

The ZAPI drive control unit is equipped with a diagnosis connector. Any changes of the factory presetting values and parameters is forbidden.

Position of connectors

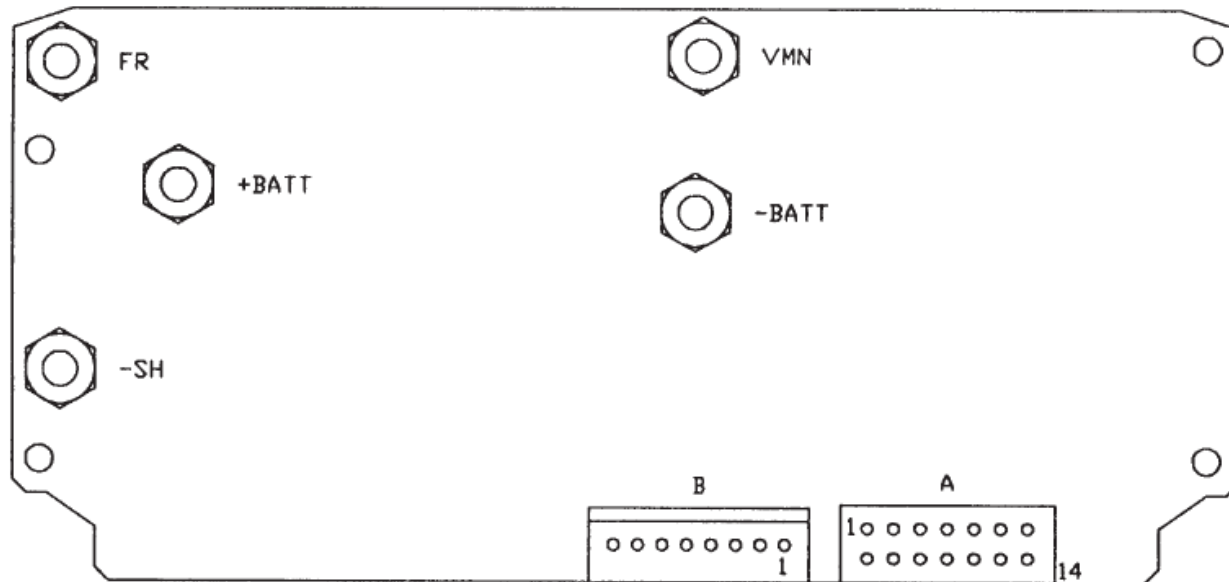

- A = Connector for relay control and control inputs ;
- B = Connector for diagnosis device and alarm LED

9 Drive Control Units

9.1 ATECH / ZAPI – DC Motor

Connectors, Description of ZAPI Drive Control

A1	<i>RV1</i>	Speed reduction no 1 input; normally close contact toward battery positive: active when pin is free.
A2	<i>IRE</i>	Europe quick inversion input; normally open contact; active when pin is connected to battery positive.
A3	<i>MT</i>	Tiller or seat micros witches; normally open contact; running is permissible when the pin is connected to battery positive.
A4	<i>NT2</i>	Output for control toward forward contactor coil negative on autostop configuration. Or output for electro-brake, by-pass, main contactor on standard configuration.
A5	<i>CH</i>	Key contact input, for chopper feeding.
A6	<i>IRZ</i>	Zapi quick inversion input, normally close contact toward battery positive: active function when pin is free.
A7	<i>RV2</i>	Speed reduction no 2 input; normally close contact toward battery positive: reduction is active when pin is free.
A8	<i>PT</i>	Positive contactors output; it provides positive for chopper's controls; decoupled from A5 input through a diode.
A9	<i>MA</i>	Forward running request input; normally open contact: request is active when contact is closed to battery positive.
A10	<i>MI</i>	Backward running request input; normally open contact: request is active when contact is closed to battery positive.
A11	<i>NT1</i>	Output for command to backward contactor coil negative on autostop configuration; or running contactors common return on standard configuration.
A12	<i>NPOT</i>	Potentiometer negative:
A13	<i>CPOT</i>	Potentiometer central: range varies either from 0.6V to 10V
A14	<i>PPOT</i>	Potentiometer positive:; output potential is 13V while output impedance is 82ohm.

9 Drive Control Units

9.1 ATECH / ZAPI – DC Motor

9.1.1 Automatic Monitoring of Components

The micro-processor executes evaluation of basic controller functions.

This evaluation concerns the following 4 states:

•Check upon switching on by key switch:

Watchdog, current sensor, power MOS FETs, contactor drive (contactor driver), direction switch, potentiometer connections, EEPROM

•Check during standstill:

Watchdog, current, power MOS FETs, contactor drive (contactor driver), potentiometer connections

•Check during ride:

Watchdog, current, power MOS FETs, contactor drive (contactor driver), potentiometer connections, closing and opening of contactors

•Permanent monitoring:

Temperature, battery voltage

Eventual error messages are displayed via flashing LED at connector B (paragraph 2). Error type can be differentiated by number of flashes.

9 Drive Control Units

9.1 ATECH / ZAPI – DC Motor

9.1.2 Diagnosis LED for Drive Module (ZAPI)

Nr.	Flash-Code	Message	Status*	Remark
1)	1	WATCH-DOG	A	Faulty electronic
2/3/4/5)	1	EEPROM	A	Faulty electronic (EEprom)
6)	2	INCORRECT START	B	Direction selected when switching on (or incorrect IR connection)
7)	3	VMN LOW	B	MOSFET short-circuited
8)	3	VMN HIGH	B	Diodes short-circuited or direction contactor stuck
9)	4	VACC NOT OK	B	Potentiometer defective
10)	5	I=0 EVER	A	No current detected during riding
11)	5	HIGH CURRENT	A	Current flow in rest state
12)	6	PEDAL WIRE KO	B	Potentiometer wiring defective
13)	7	TEMPERATURE	C	Temperature > 76°C
15)	8	DRIVER 1 KO	A	NT1 driver short-circuited
16)	8	DRIVER 1 SIC KO	A	Contacto coil short-circ. at NT1
17)	8	DRIVER 2 KO	A	NT2 driver short-circuited
18)	8	DRIVER 2 SIC KO	A	Contacto coil short-circ. at NT2
19)	8	DRIVER SHORTED	B	Driver short-circuited (NT1)
20)	8	CONTACTOR OPEN	B	Contacto does not close
21)	9	POSITION HANDLE	B	Handle micro-switch not actuated
22)	9	INVERSION	B	Deadman key (IR) actuated or incorrectly wired
23)	9	FORW.+BACKW.	B	Both directions simultaneously actuated
24)	permanent flash	BATTERY	C	Battery low
	*	A = switch off system, remedy and switch on again		
		B = remedy and actuate direction again		
		C = status display and eventually required measures controlled by software		

9 Drive Control Units

9.1 ATECH / ZAPI – DC Motor

9.1.3 Explanations of Error Messages

1) WATCH-DOG

Test in rest position as well as during riding; internal auto-test function of hard- and software; replace controller in case of error alarm!

2) EEPROM PAR. KO

Error in the memory area containing the adjustment parameters. System switches off. Replace logic if error persists after switching key switch off and on! If alarm disappears mind the fact that the saved parameter values are deleted. (—> basic setting)

3) EEPROM CONF. KO

Error in the memory area containing the configuration data of the controller. Replace logic if error persists after switching key switch off and on! If alarm disappears mind the fact that the saved configuration is deleted. (—> basic setting)

9 Drive Control Units

9.1 ATECH / ZAPI – DC Motor

4) EEPROM DATA KO

Data in the memory area which controls the hourmeter are faulty.

If alarm disappears, after switching key switch off and on, mind the fact that the hourmeter is reset to zero.

5) EEPROM OFF LINE

Error in the non-volatile memory containing hourmeter values, programmable parameters and saved alarms.

Replace controller if error persists after switching key switch off and on!

9 Drive Control Units

9.1 ATECH / ZAPI – DC Motor

6) INCORRECT START

Incorrect sequence of start conditions. Depending on SAFETY SWITCH programming, system starts if the following sequence is respected:

- key switch – handle micro-switch – direction switch (HANDLE)
- key switch - direction switch(FREE)
- key switch + seat contact switch - direction switch (SEAT)

Possible causes:

- a)** Direction or handle micro-switch stuck.
- b)** Operator did not respect sequence.
- c)** Incorrect wiring.

If no external fault can be detected, replace controller!

9 Drive Control Units

9.1 ATECH / ZAPI – DC Motor

7) VMN LOW

Test in rest state and during ride until VMN is pulsed out to up to 80%;

If contactors are open, voltage at VMN connection normally amounts to 50% VBatt. If this voltage value is insufficient (< 30% VBatt) an alarm is output. Possible causes:

- a)** Master contactor (if fitted) does not close or is not connected at all
- b)** Short-circuit between connection VMN and -Batt (metal particles or other.) (disconnect cable at connection VMN, switch on, error disappears)
- c)** Power MOSFET short-circuited or permanently triggered by logic; (disconnect cable at connection VMN, switch on, error persists, replace controller)
- d)** Bypass contactor (if fitted) stuck or opens too slowly

9 Drive Control Units

9.1 ATECH / ZAPI – DC Motor

8) VMN HIGH

Test in rest state;

If contactors are open, voltage at VMN connection normally amounts to 50% VBatt. If this voltage value is exceeded (> 70% VBatt), an alarm is output. Possible causes:

- a)** A direction contactor is permanently closed since mechanically blocked or permanently driven (incorrect wiring of contactor coil)
- b)** Short-circuit between field and armature winding of motor
(disconnect cable at connection VMN, switch on, error disappears, repair motor)
- c)** Incorrect connection of motor cable (check field and armature winding)
- d)** Power circuit of controller defective (free wheeling or braking diodes short-circuited) (disconnect cable at connection VMN, switch on, error persists, replace controller)

9 Drive Control Units

9.1 ATECH / ZAPI – DC Motor

9) VACC NOT OK

Test in rest state;

Alarm is displayed if, referred to the saved minimum value, potentiometer voltage is higher than 1V.

Possible causes:

- a)** Wire broken at potentiometer or inductive sensor.
- b)** Potentiometer or the inductive sensor is defective.

10) I=0 EVER

Test during ride;

If current does not exceed a determined minimum value during ride, an error message appears and the system switches off.

Possible causes:

- a)** Resistance of motor is excessive since motor is defective or contact of carbon brushes is not okay
- b)** The current sensor is defective (replace controller)

9 Drive Control Units

9.1 ATECH / ZAPI – DC Motor

11) HIGH CURRENT

Test in rest state – contactor open;

If measured current is $>50A$, alarm is output and the system switches off. The current sensor is defective (replace controller!)

12) PEDAL WIRE KO

If no voltage is measured at pin NPOT (A12), to which the negative wire of the potentiometers is connected, an alarm is output.

Possible causes:

- a)** Wire rupture at pin PPOT (A14)
- b)** Wire rupture at pin NPOT (A12)
- c)** Potentiometer is defective (infinite resistance)
- d)** Potentiometer resistance $>47\text{ kOhm}$

9 Drive Control Units

9.1 ATECH / ZAPI – DC Motor

13) TEMPERATURE

This message signals that controller temperature has exceeded 76°C.

Maximum current is reduced step by step to zero at a temperature of 86°C. Possible causes:

- a) If the alarm is output immediately after system ON with cold controller, temperature monitoring is faulty (replace controller!)
- b) If the alarm is output after relatively short period of operation, heat is insufficiently dissipated (check installation and fixing screws)

14) NO FULL COND.

Test during full ride;

If during full ride, the voltage at connection VMN is $> 1/3 V_{Batt}$, the diagnosis circuitry is faulty and the system switches off.

If error persists, replace controller (logic unit).

9 Drive Control Units

9.1 ATECH / ZAPI – DC Motor

15) DRIVER 1 KO

If voltage at connection NT1 (A11) does not correspond to determined value, an alarm is output and the system switches off.

Possible causes:

- a) Wire broken at connection NT1 (A11) or coil of reverse direction contactor is defective.
- b) The internal MOSFET driver is short-circuited (replace controller!)

16) DRIVER 1 SIC KO

If current load at contactor driver controlling the output NT1 (A11) is excessive, an alarm is output and the system switches off.

Possible causes:

- a) Short-circuit of the wire at connection NT1 (A11) to +Batt
- b) Coil of connected contactor short-circuited or current consumption > 5A

9 Drive Control Units

9.1 ATECH / ZAPI – DC Motor

17) DRIVER 2 KO

If voltage at connection NT2 (A4) does not correspond to determined value, an alarm is output and the system switches off.

Possible causes:

- a) Wire broken at connection NT2 (A4) or coil of forward direction contactor is defective.
- B) The internal MOSFET driver is short-circuited (replace controller!)

18) DRIVER 2 SIC KO

If current load at contactor driver controlling the output NT2 (A4) is excessive, an alarm is output and the system switches off.

Possible causes:

- a) Short-circuit of the wire at connection NT2 (A4) to +Batt
- b) Coil of connected contactor short-circuited or current consumption > 5A

9 Drive Control Units

9.1 ATECH / ZAPI – DC Motor

19) DRIVER SHORTED (only H0 STANDARD TRACT.)

If voltage at connection NT1 (A11) does not correspond to determined value, an alarm is output and the system switches off.

Possible causes:

- a) Wire broken at connection NT1 (A11) or coil of forward or reverse direction contactor is defective.
- b) The internal MOSFET driver is short-circuited (replace controller!)

20) CONTACTOR OPEN

Test upon actuation of driving direction;

It is checked whether the selected direction contactor closes by measuring the VMN value. If value is incorrect, an alarm is output.

Proceed as follows to remedy:

9 Drive Control Units

9.1 ATECH / ZAPI – DC Motor

When does error occur?	First test	Result	Second test	Result	Error
In forward direction only	Forward direction contactor closes for 0.3 sec. before opening	yes	-->	-->	A1
		no	At the forward direction contactor, a voltage applies to the coil for 0.3 sec.	yes	B1
				no	C1
In reverse direction only	Reverse direction contactor closes for 0.3 sec. before opening	yes	-->	-->	A2
		no	At the reverse direction contactor, a voltage applies to the coil for 0.3 sec.	yes	B2
				no	C2
In both directions	Forward or reverse direction contactor (depending on selected direction) closes for 0.3 sec. before opening	yes	-->	-->	A3
		no	At the forward or reverse direction contactor (depending on selected direction), a voltage applies to the coil for 0.3 sec	yes	B3
				no	C3

9 Drive Control Units

9.1 ATECH / ZAPI – DC Motor

- A1** The make contact of the forward direction contactor (TA) or the break contact of the reverse direction contactor (TI) is soiled or blocked. Clean contacts or, if required, replace contactor group.

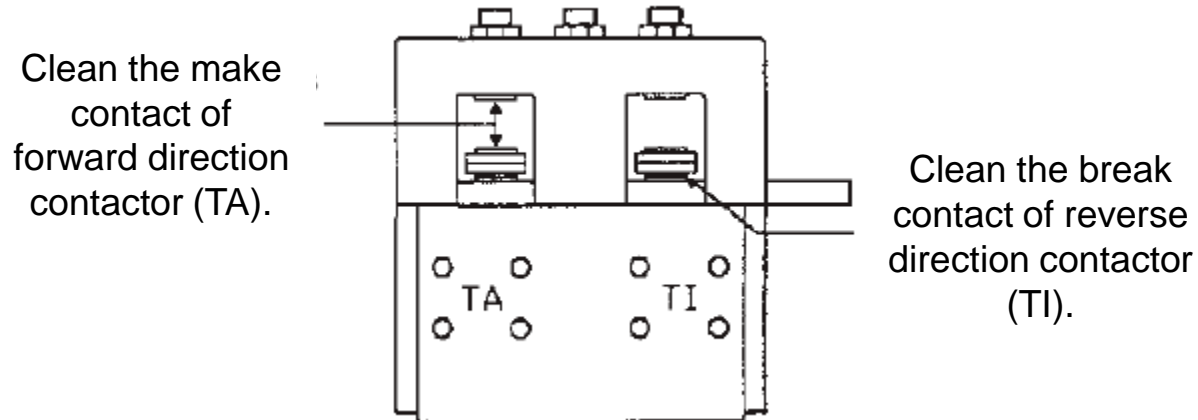

9 Drive Control Units

9.1 ATECH / ZAPI – DC Motor

- A2** The break contact of the forward direction contactor (TA) or the make contact of the reverse direction contactor (TI) is soiled or blocked. Clean contacts or, if required, replace contactor group.

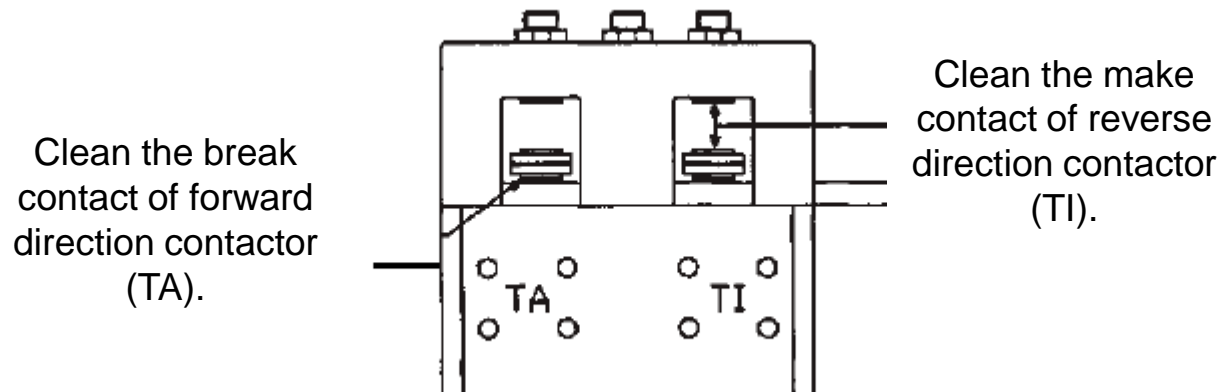

9 Drive Control Units

9.1 ATECH / ZAPI – DC Motor

A3

No connection to motor:

- Carbon brushes without contact to collector (Fig. 1)
- Connection cable of carbon brushes interrupted (Fig. 2)
- Motor winding defective or motor cable interrupted
- Incorrect connection of motor

Fig. 1

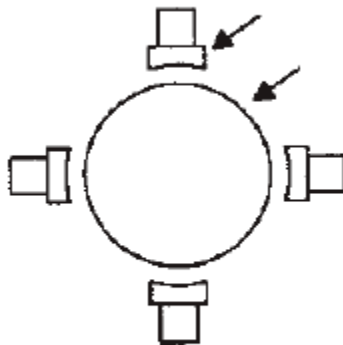
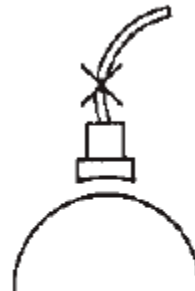

Fig. 2



9 Drive Control Units

9.1 ATECH / ZAPI – DC Motor

B1 The forward direction contactor is correctly driven but does not close.

- Contactor coil is defective; use ohmmeter to measure resistance
- Contact is mechanically blocked
- Nominal voltage of contactor coil higher than battery voltage

B2 The reverse direction contactor is correctly driven but does not close.

- Contactor coil is defective; use ohmmeter to measure resistance
- Contact is mechanically blocked
- Nominal voltage of contactor coil higher than battery voltage

B3 The forward or reverse direction contactor is correctly driven but does not close.

- Contactor coils are defective; use ohmmeter to measure resistance
- Contacts are mechanically blocked
- Nominal voltage of contactor coils higher than battery voltage

C1 No voltage supply to coil of the forward direction contactor. Check connector and cable from contactor coil to positive supply and to pin A4 (NT2).

C2 No voltage supply to coil of the reverse direction contactor. Check connector and cable from contactor coil to positive supply and to pin A11 (NT1).

C3 No voltage supply to coils of the forward and reverse direction contactor. Check connector and cable from contactor coils to positive supply and to pins A4 (NT2) and A11 (NT1).

If no faults are detected for the items C1, C2, C3, replace logic.

9 Drive Control Unit

9.1 ATECH / ZAPI – DC Motor

21) POSITION HANDLE

If upon switching on, the handle micro-switch has already been actuated, error is signalled (only if SAFETY SWITCH is programmed to HANDLE). Possible causes:

- a) Handle micro-switch stuck
- b) Incorrect operation

22) INVERSION

If upon switching on, the emergency reverse (deadman) button is depressed, an alarm is output. Possible causes:

- a) Micro-switch for emergency reverse stuck
- b) Incorrect operation
- c) Incorrect wiring or programming

23) FORW - BACK

An error is displayed if two directions are simultaneously active. Possible causes:

- a) Wiring defective.
- b) Direction micro-switch stuck. If none of the causes applies, replace logic!

24) BATTERY

Battery discharged i.e. battery voltage has fallen below 60% of nominal voltage. An alarm is output. The system switches off but can be re-started. Maximum current then will be reduced to 50% of programmed maximum current value.

9 Drive Control Unit

9.2 DMC – AC Motor

The DMC-drive control unit is equipped with a diagnosis connector. If not explicitly stated in the service manuals, a change of the factory preset parameters and values is forbidden. Currently only the diagnosis with the blinking codes at the Trip-LED is used for the Drive control unit.

9.2.1 Description of the connectors

M1; M2; M3 – Motor connectors

B+; B- – Power supply from Battery

A – Machine communication
connector (16-pole)

B – Programming connector (8-pole)

C – Motor Feedback (6-pole)
(Encoder and Temperature)

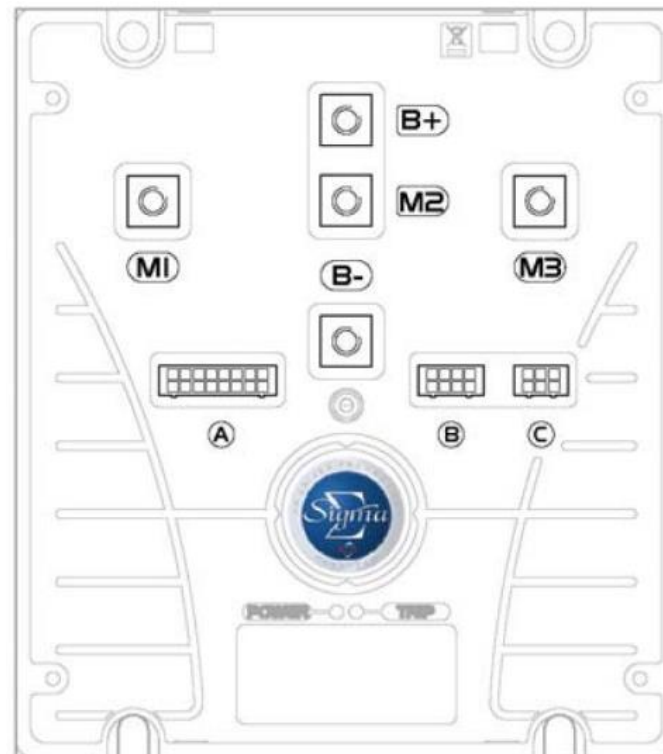

9 Drive Control Unit

9.2 DMC – AC Motor

A1 – Forward switch (activ, if B- is present)

A2 – Reverse switch (activ, if B- is present)

A3 – enable drive mode from switch –S08 (activ, if B- is present)

A4 – enable drive mode from machine control unit (Seat contact switch) (activ, if B- is present)

A5 – Max speed (activ, if B- is present)

A6 – always at B-

A7 – Input from foot brake switch S10; if B- is present, machine is decreased to standstill

A8 – Potentiometer (yellow)

A9 – Feedback from Potentiometer (RED)

A10 Control voltage from Key Switch

A11 – Voltage for low current consumers (max 3A) (e.G. –K05 und Brake coil)

A12 – Release Main kontaktor (B-) –K05 – Main Power supply for the drive control unit

A13 – Release Brake (B-)

A14 – not used

A15 – 12V Power supply for the Encoder

A16 – 5V Power supply for the potentiometer (green)

9 Drive Control Unit

9.2.2 Error codes DMC Control Unit – AC Motor

Diagnosis Overview DMC PAC212TS01 – Hako B115R			
Led	Calibrator Message	Description	Action
Error Messages – LED Blinking Code			
<i>Warning Faults</i>			
ON	None (lowest Priority)	Controller operational and OK	No action required
1	Handbrake on	Handbrake switch closed	Release handbrake
2	Voltage getting low	Battery voltage getting low (normally during driving)	Charge Battery
3	not used		
4	Voltage getting high	Battery voltage getting too high (normally during braking)	Reduce braking levels or vehicle Speed

9 Drive Control Unit

9.2.2 Error codes DMC Control Unit – AC Motor

Led	Calibrator Message	Description	Action
Error Messages – LED Blinking Code			
<i>Warning Faults</i>			
5	Motor hot	Thermal cutback, allow the motor to cool down	Use vehicle within it's specifications
6	Controller hot	Thermal cutback, allow the controller to cool down	Check heat sinking and specifications
7	Adjustments out of range	One or more adjustments are out of range	Parameters are preadjusted ex factory. Parameter change is not allowed. Replace the controller
8	Default settings restored	Default settings restored	Check adjustments for correct values
9	E-prom cannot be accessed	E-prom not accessible	Internal supply voltage below 12 volt. Replace control unit.

9 Drive Control Unit

9.2.2 Error codes DMC Control Unit – AC Motor

Led	Calibrator Message	Description	Action
Error Messages – LED Blinking Code			
<i>Main Faults (Recycle to neutral)</i>			
10	2 Direction fault	Both forward and reverse selected. Recycle both directions and FS1.	Check direction switch and wiring.
11	decontrol is missing	Signal from -A1.X10.1 is missing	Check wiring and voltage potential (Batt.: B-)
12	Sequence fault	Forward / reverse or FS1 closed at key on.	First key on, then close switches.
13	Accelerator high at first power up	Accelerator voltage > 50% at key on.	Check controller settings and accelerator mechanics.
14	Inching or belly fault	Forbidden input selected with inching (FS1/Seat/Handbrake) or belly switch timeout	Open switches / check wiring
15	Voltage too low	Internal 12V supply low.	Check battery capacity / charge level / controller voltage rating / settings
16	not used		

9 Drive Control Unit

9.2.2 Error codes DMC Control Unit – AC Motor

Led	Calibrator Message	Description	Action
Error Messages – LED Blinking Code			
<i>Main Faults (Recycle to neutral)</i>			
17	Voltage too low	Battery voltage too low	Check battery capacity / charge level / controller voltage rating / settings
18	High sided Mosfet short circuit	High sided Mosfet short circuit	Check motor insulation and line contactor, if OK replace controller
19	Low sided Mosfet short circuit (drive)	Low sided Mosfet short circuit (drive)	Check motor insulation, if OK replace controller
<i>Hard Faults (Recycle key-switch)</i>			
20	Hardware over current (AC)	Hardware over current circuit active	Check adjustments and motor setup
21	Contactor coil short circuit	Contactor coil S/C or driver or wiring open circuit	Check contactor coils and wiring

9 Drive Control Unit

9.2.2 Error codes DMC Control Unit – AC Motor

Led	Calibrator Message	Description	Action
Error Messages – LED Blinking Code			
<i>Hard Faults (Recycle key-switch)</i>			
22	Voltage too high	Battery voltage too high (normally during braking)	Reduce braking levels or vehicle Speed, defective battery
23	Low sided Mosfet short circuit (neutral)	Low sided Mosfet short circuit in neutral	Check motor insulation and line or regen contactor, if OK replace controller
24	HWFS not working	Hardware failsafe cannot disable hardware	Check wiring / replace controller
25	Contactor fault	Contactor open- or short circuit	Check all contactors for open- and shortcircuit
26	Current measurement fault	Current measurement system faulty.	Replace controller
27	Low side Mosfet short circuit	Low sided Mosfet short circuit before line contactor closed	Check motor insulation and line contactor, if OK replace controller

9 Drive Control Unit

9.2.2 Error codes DMC Control Unit – AC Motor

Led	Calibrator Message	Description	Action	
Error Messages – LED Blinking Code				
<i>Hard Faults (Recycle key-switch)</i>				
28	Wire off detected	Sub 0	No wire off detected	Check the related circuits
		Sub 1	motor connection	
		Sub 2	short circuit magnetic brake	
		Sub 3	wire off magnetic brake	
		Sub 4	wire off motor sensor	
		Sub 5	wire off drive pedal	
		Sub 6	Wire off thermo switch motor	
29	not used			
30	Over speed	Over speed or wrong encoder teeth setting	Check encoder-wiring	

9. Drive Control Unit

9.3 Drive motor and Gearbox DC and AC

The quantities and qualities of the oil filling in the drive motor gearboxes are as follows:

DC- Drive: 0,5l - Castrol Alphasyn EP 150

AC-Drive: 0,5l - Fuchs Renolin CLP 100

Tightening torques:

- Fixing screws for the motor on the gearbox (Fig. 9.1- a): 23Nm
- Wheel bolts (Fig. 9.1- b) : 42Nm
(Replace the screws PN 01171260 – M8x20 – at wheel change)
- Fixing screws for the drive unit at the chassis (Fig. 9.1- c): 48Nm
(PN 00055460 - 6 Pc. M10 x 16)

9. Drive Control Unit

9.3 Drive motor and Gearbox DC and AC

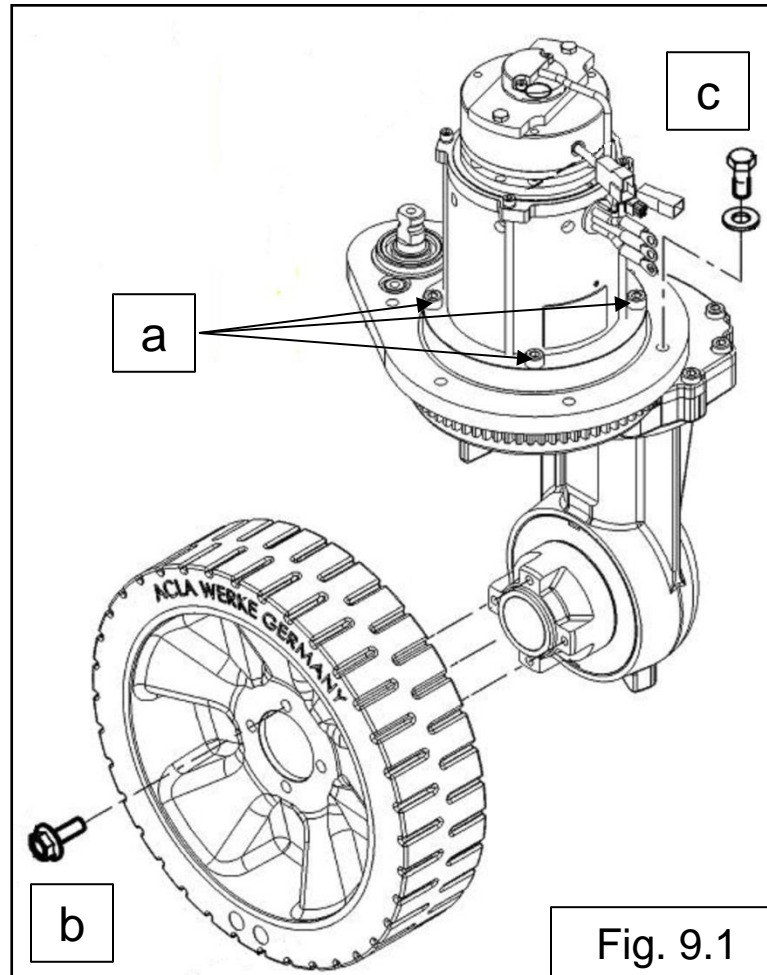

10. Error Reference Chart with Information on Service Display

Error number / Message number	Error source	Comment
1.2.5.2.	Thermostatic switch, brush 1/2	Check temperature of brush motors; check power consumption of brush motors; check cabling of thermostatic switch (connector X3 and X4) of brush motors (series circuit). Inputs -A1.X9:1 and 11 power consumption per brush motor max. PB 650 - 30A; PB 750, PB 900, CB 700, CB 850 - 40A
1.2.6.1.	Blocking protection, brush 1/2	Do brush motors run smoothly? Check power consumption? (See 1.2.5.2.)
1.2.6.3.	Blocking protection, brush lifting element 1/2	Stiff? Brush head jammed?
1.4.6.1.	Blocking protection, squeegee lifting element	Stiff? Squeegee jammed?
1.4.6.3	Blocking protection, suction turbine	Short circuit at suction motor output -X14.1 / - X15.1

10. Error Reference Chart with Information on Service Display

Error number / Message number	Error source	Comment
3.1.6.E.	Power fuses (group signal)	Group signal, fuses -F02; -A01.F2
3.2.6.5.	Backup battery "weak"	Message appears after the "Last error" display and before the operating hour counter; remains 5 s or when working unit is ON; replace BackUp Batterie A01:G01 (on the back of the Control Unit); Type: "CR2032"
3.2.6.6.	Backup battery "empty"	Message appears after the "Last error" display and before the operating hour counter, remains until working unit is ON; replace BackUp Batterie A01:G01 (on the back of the Control Unit); Type: "CR2032"
3.3.1.1.	Service interval has expired	Message appears after the "Last error" display and before the operating hour counter; remains 5 s or when working unit is ON (If a service intervall was enabled - via PC based diagnosis)

10. Error Reference Chart with Information on Service Display

Error number / Message number	Error source	Comment
3.3.6.2.	Group signal, low power outputs	Overload of small consumers (solenoid valve, buzzer)
3.4.1.1.	Drive rheostat	Check drive direction switch and cabling
3.4.5.1.	Drive motor overheated	Check thermostatic switch and cabling of drive motor, connector X10 input A1.X9:2 and 12
3.6.6.4.	Seat switch manipulation	The seat contact switch was closed longer than 6 hours. The working units are switched off; after the key switch has been set to "OFF" and "ON" again, also the drive control unit is blocked. To reset the message, a change of signal must occur at input -A01.X9:8 / 18. (see chapter 2.2.3)

10. Error Reference Chart with Information on Service Display

Error number / Message number	Error source	Comment
4.5.2.5.	Operating panel not detected	Check connection cable for control unit (-A01) - operating panel (-A02). This error only occurs when switching the machine on
4.5.3.5.	Operating panel response missing (timeout)	Check connection cable for control unit (-A01) - operating panel (-A02). This error only occurs during operation of the machine on
4.6.1.2.	Internal error control system	If error occurs repeatedly, even after switching the machine off and on again, replace the control unit (-A01)

10.1 Service-Intervall – 3.3.1.1

On from Software release 1.002 the service intervall is enabled ex factory in the Scrubmaster B115R. The service intervall is activated after 250 working hours of the machine, or after 365 days; depending on wich event occurs first.

This isn't an error code; This is an operator information that indicates a necessary service to the machine. This operator information doesn't impair the function of the machine. This information is displayed for 5 sec, everytime the machine is switched on; then the machine can be used as usual.

You can skip this information by activation of any function (drive, scrubbing, suction or suction and scrubbing).

Activation or deactivation and reset of the service interval is possible only with the Hako-Diagnosis System.

This requests the same preconditions like the flashing of a new control unit:

- Service-Computer with up to date Hako-Diagnosis-Software (and COM-Port)
- Interface PN 03501750 or PN 03502430
- Diagnostic Cable PN 03502110

10.1 Service-Intervall – 3.3.1.1

Establish a connection between the Service-Computer and the machine control pcb and start the diagnosis software. Click on the tab „System“ of the diagnosis menu and choose „Write event“(Fig. 10.1).

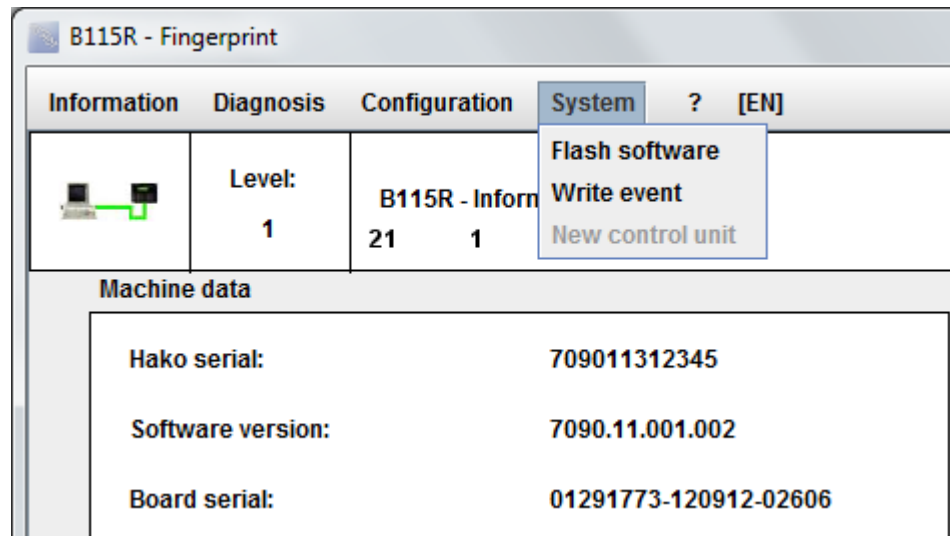

Fig.10.1

Then the window for the service interval is opened (Fig. 10.2). There the Service alert can be deactivated with the button „Switch Off service alert“, or switched On or restarted with the button „Set Service alert to 365/250“. Confirm the selection with the button „Save event“.

10.1 Service-Intervall – 3.3.1.1

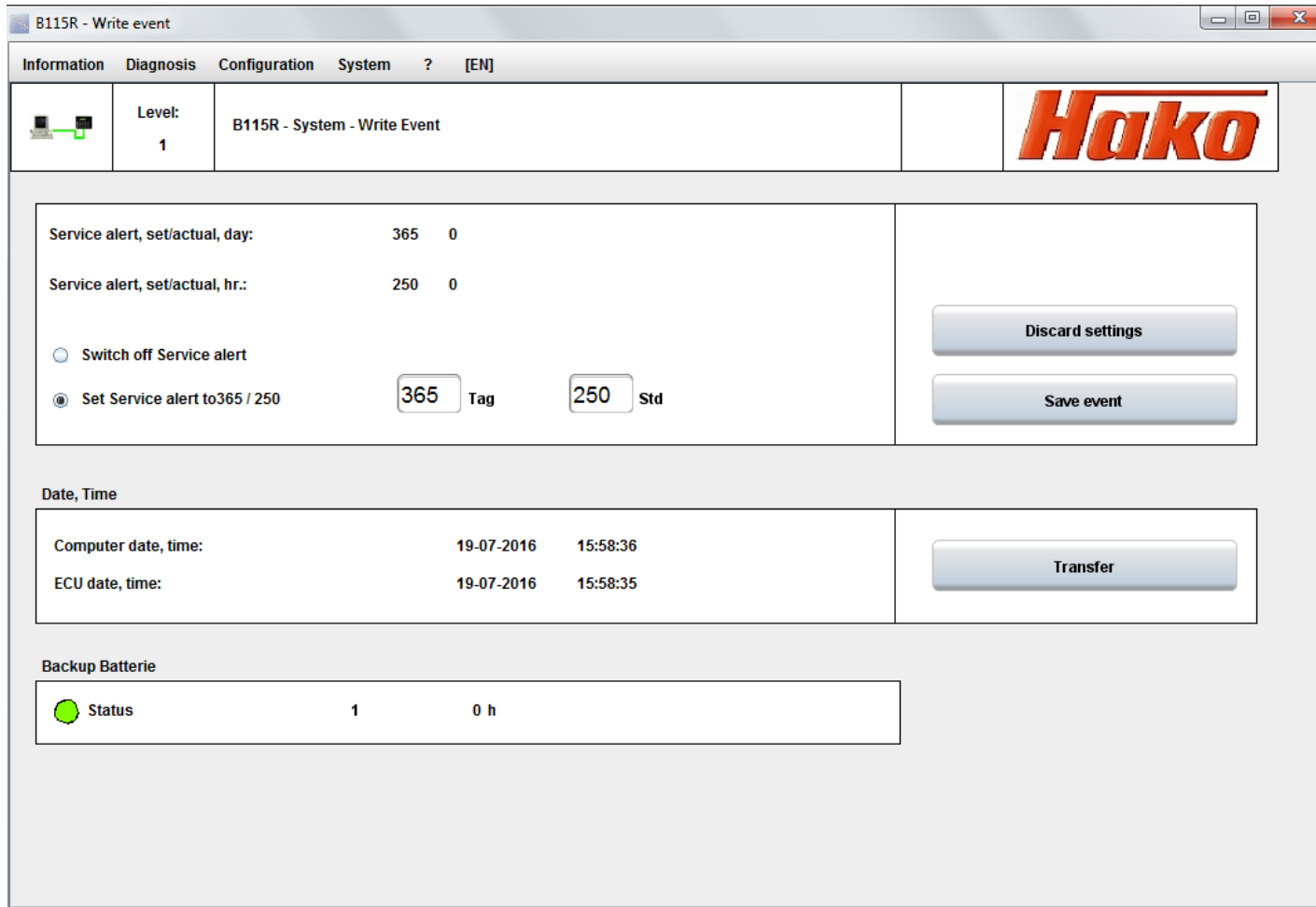

Fig.10. 2

11. Brakes

The brake needs to be able to stop the machine within 0.19 m per km/h on plane ways.

At a maximum speed of 6.5 km/h this means, that the maximum stopping distance may be 1.235 m. This has to be checked after working on the brake system and during the regular maintenances.

Regarding the AC gear this value has to be reached if the brake pushbutton is pressed.

11. Brakes

11.1 Adjustment of Brake (DC-Motor)

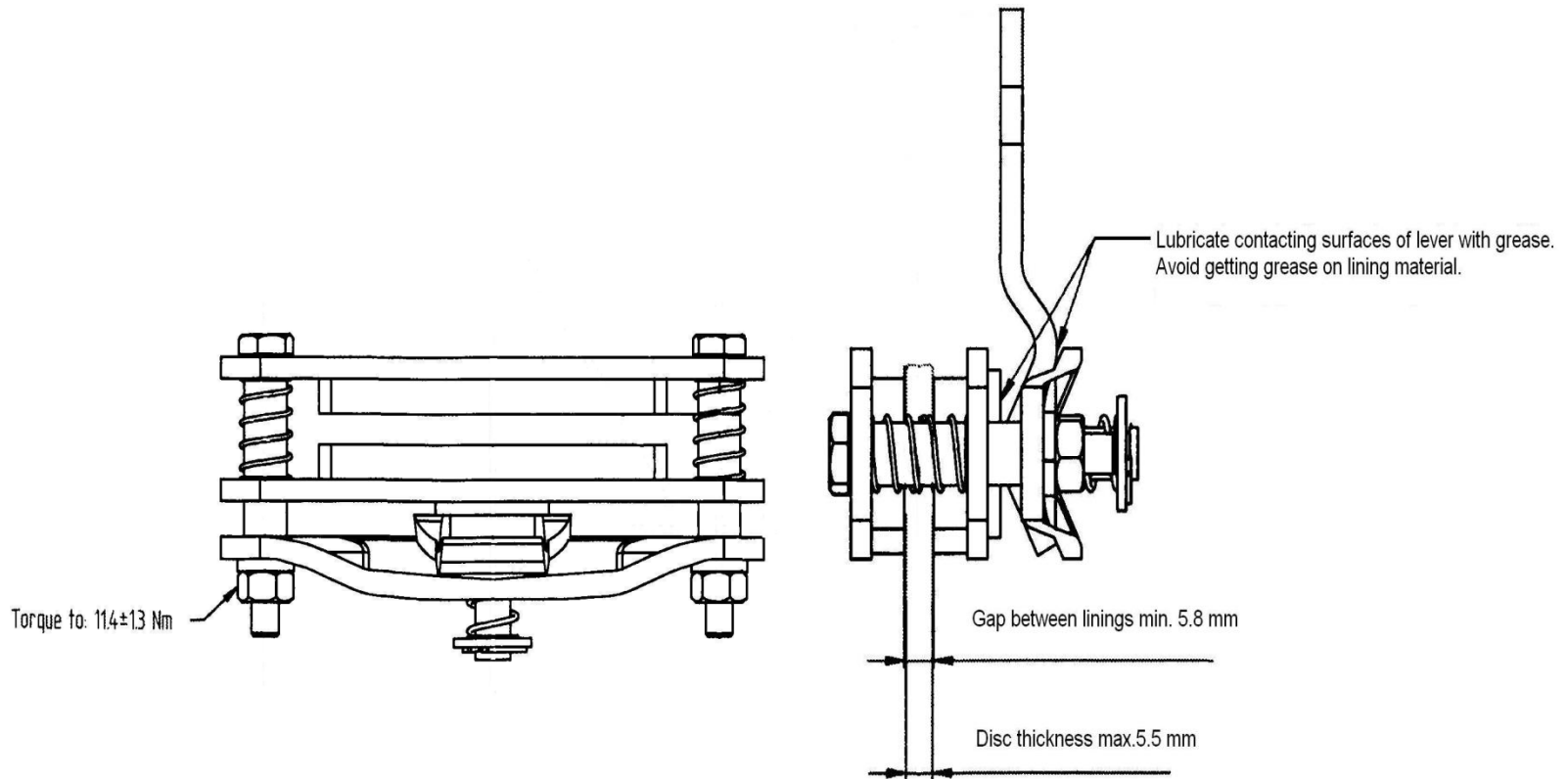

11. Brakes

11.2 AC-Motor

The AC-motor has got a magnetic brake, which is directly installed on the motor shaft. If the machine is not in a driving mode, the brake is active.

The machine can only be pushed, if the key switch of the machine is „on“ and as long as the unlock button (1) is pressed.

- Set the key switch to "On".
- Press and hold the Unlock button and, at the same time, push the vehicle.

The Unlock button is situated at the front left of the machine (viewed in driving direction) under the chassis (see picture below).

On the plug – X38 (on the left side at the steering column behind the maintenance cover), the brake can be released by means of an external voltage source of abt. 18V – 24V. Two 9V monobloc Batteries connected in line are sufficient.

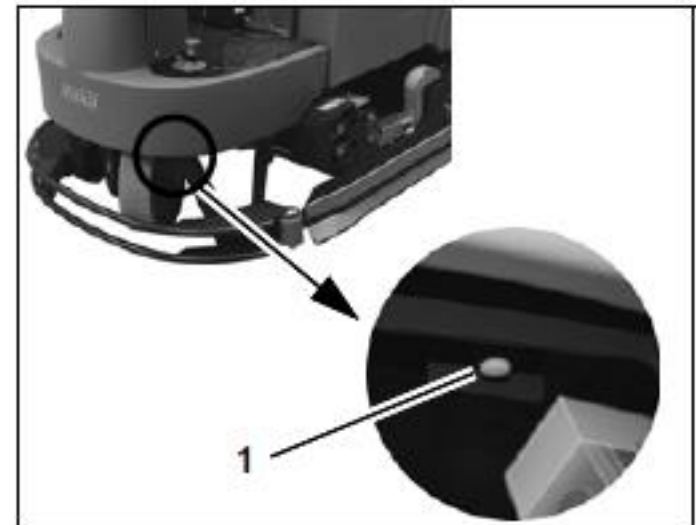

12. Options

The following options are available for vehicles in the Hakomatic B115R series:

- Silence kit (99.7730.10)
- Acoustic warning signal (99.7091.00)
- Chemical dosage (99.7678.45)
- Scrubbing-vacuum tool (99.7376.02)

12.1 Option, Silence Kit

To activate the Silence Kit option, access the programming level as described in Chapter 2.2.4. Then define the parameter settings as indicated in the table below and save the settings.

Chapter	Configuration	Contents	Description	B115 / PB650	B115 / PB750 / CB700	B115 / PB900 / CB850
				99-7090-51	99-7090-11 / 21 / 35 / 41	99-7090-81 / 91
1	0		Silence Kit			
1	0	0	Not available	d	d	d
1	0	1	Available	x	x	x

12.1 Option, Silence Kit

Silent Kit

Conversion kit

The conversion kit is comprised of the following parts:

- Insulation pad
- Assembly manual

Assembling the insulation pad



Switch the vehicle off and disconnect the battery plug before beginning assembly work!

1. Disassemble the cover (Fig. 12.1/1) and pull off the pipe clip (Fig. 12.1/2) for the hose of the fill level indicator.
2. Unscrew the holder (Fig. 12.1/3).
3. Pull out the clean water hose (Fig. 12.1/4) and waste water hose (Fig. 12.1/5).

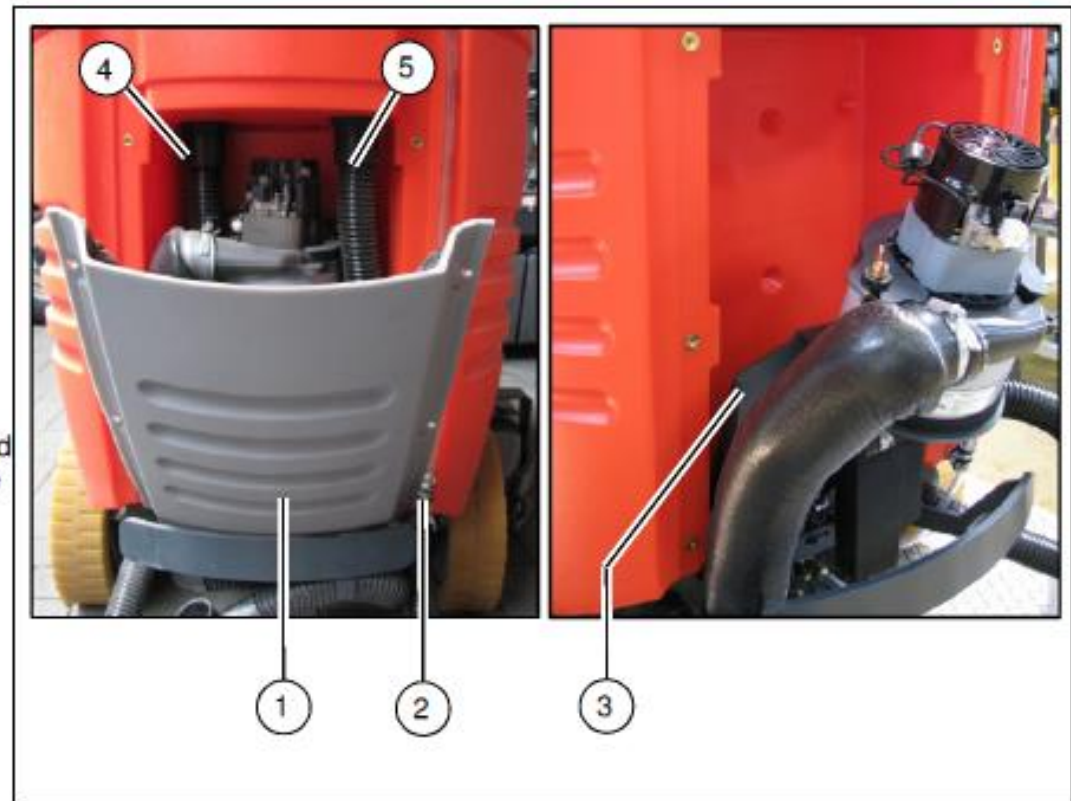

Fig. 12.1

12.1 Option, Silence Kit

4. Adhere the insulation pad (Fig. 12.2/1) in place.
5. Replace the clean water hose and waste water hose.
6. Reassemble the holder (Fig. 12.2/2), cover (Fig. 12.2/3) and fill level indicator (Fig. 12.2/4).

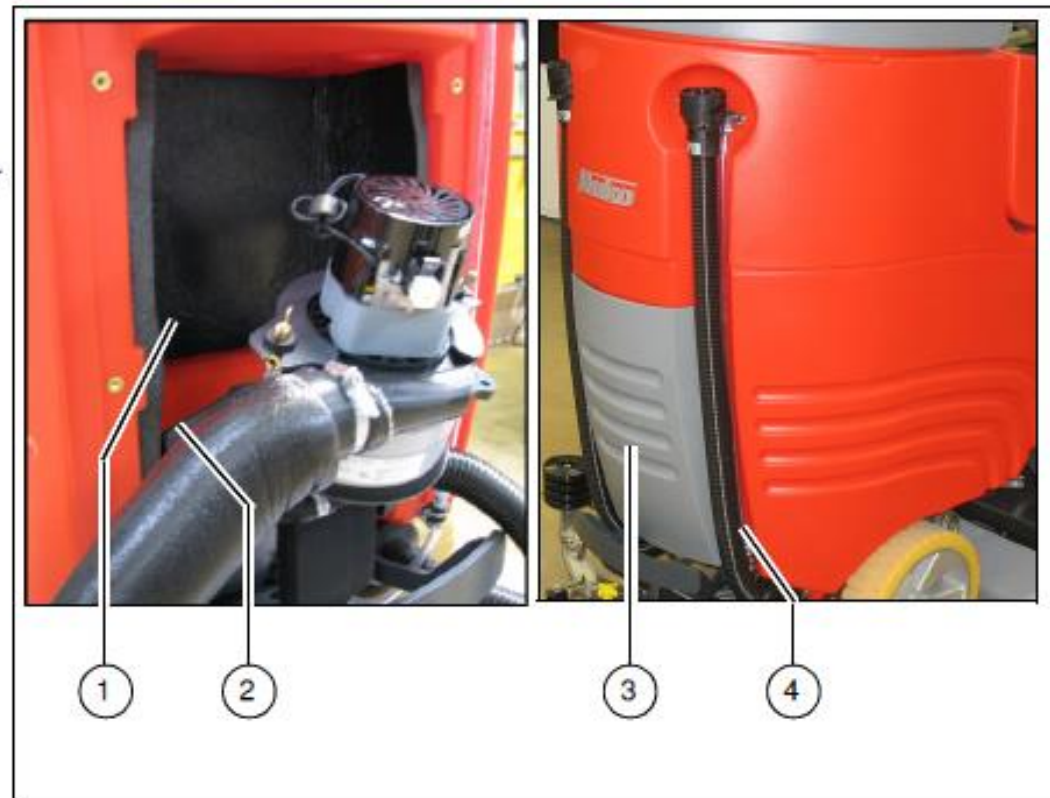

Fig.12. 2

12.2 Option, Acoustic Warning Signal

To activate the Acoustic Warning Signal option, access the programming level as described in Chapter 2.2.4. Then define the parameter settings as indicated in the table below and save the settings. The switching contact of the cable harness is connected to connector -X10 on cable harness W3. This is input -A01:X9.9 + 19 on control unit -A01.

Chapter	Configuration	Contents	Description	B115 / PB650	B115 / PB750 / CB700	B115 / PB900 / CB850
				99-7090-51	99-7090-11 / 21 / 35 / 41	99-7090-81 / 91
1	1		Acoustic Warning Signal			
1	1	0	Not available	d	d	d
1	1	1	Available	x	x	x

12.3 Option, Chemical Dosage

To activate the Chemical Dosage option, access the programming level as described in Chapter 2.2.4. Then define the parameter settings as indicated in the table below and save the settings.

Chapter	Configuration	Contents	Description	B115 / PB650	B115 / PB750 / CB700	B115 / PB900 / CB850
				99-7090-51	99-7090-11 / 21 / 35 / 41	99-7090-81 / 91
1	2		Chemical Dosing System			
1	2	0	Not available	d	d	d
1	2	1	Available	x	x	x

12.3 Option, Chemical Dosage

1 On-board Chemical Dosage

1.1 Conversion kit

The conversion kit is comprised of the following parts:

- Hose pump
- Canister
- Holder for canister
- Flow meter
- Dosing hose
- Non-return valve
- T-piece
- Fuse
- Relays
- Cable harnesses, standard parts, labels
- Assembly manual
- Hoses

12.3 Option, Chemical Dosage

1.2 Assembling the canister holder



Switch the machine off and disconnect the battery plug!

1. Assemble the holder (Fig. 1/1) of the canister (Fig. 1/2) to the electrical box cover (Fig. 1/4) using hexagon bolts, nuts and washers.
2. Mount the cable clip (Fig. 1/3) on the holder (Fig. 1/1).
3. Insert the canister (Fig. 1/2).



To prevent damage to the electronics, the screws must be inserted on the inside!

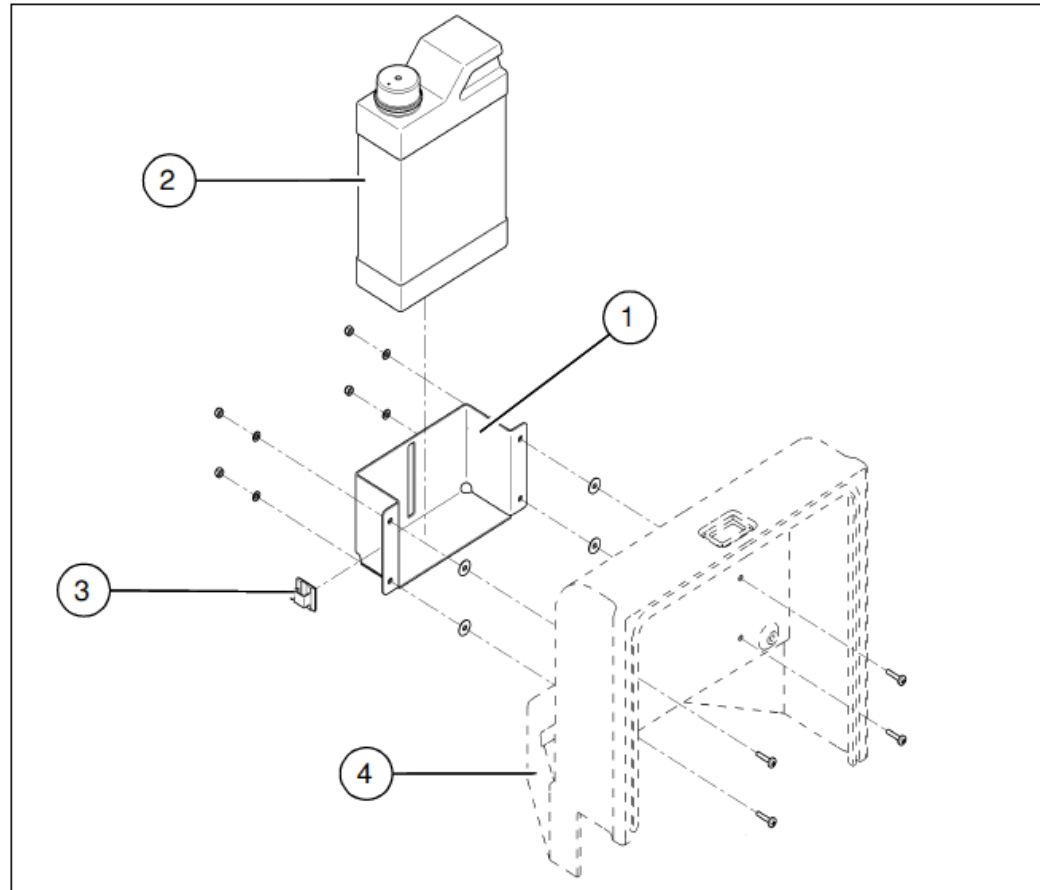

Fig. 1

12.3 Option, Chemical Dosage

1.3 Assembling the dosing pump

1. Assemble the dosing pump (Fig. 2/1) on the left-hand holder (Fig. 2/2) of the deflector.
2. Clean the surface and attach the fast emptying label (Fig. 2/3).
3. Fix the cable harness with cable ties. Refer to the circuit diagram for the electrical connection.

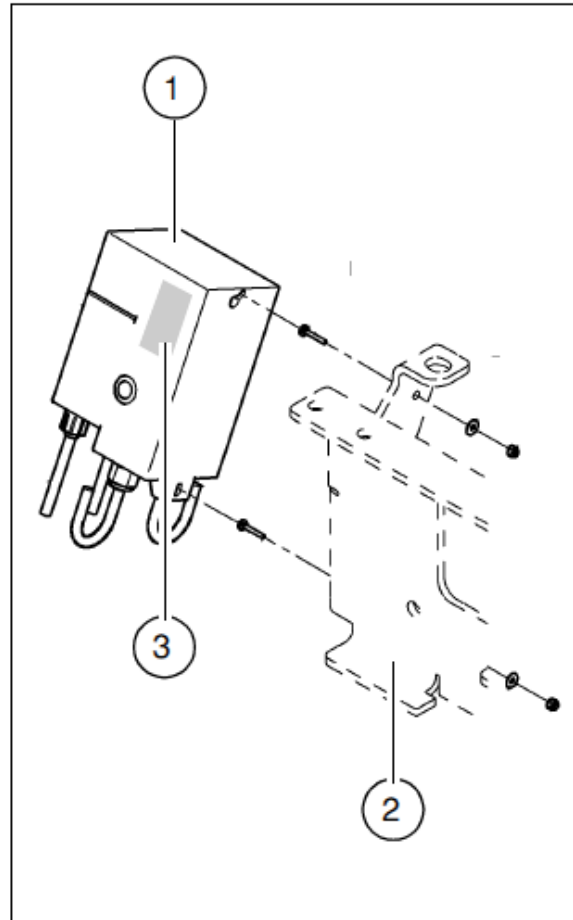

Fig. 2

12.3 Option, Chemical Dosage

1.4 Assembling the flow meter

1. Shorten the water hose installed between the relief valve and water pump to 110 mm and the remainder to 70 mm.
2. Install the 110 mm water hose (Fig. 3/1) between the flow meter (Fig. 3/2) and relief valve (Fig. 3/4) using hose clamps.
3. Install the 70 mm water hose (Fig. 3/3) between the flow meter (Fig. 3/2) and water pump using hose clamps.



Observe the flow direction on the flow meter!

4. Fix the protective cap and connector on the flow meter using cable ties.
5. Fix the cable harness with cable ties. Refer to the circuit diagram for the electrical connection.

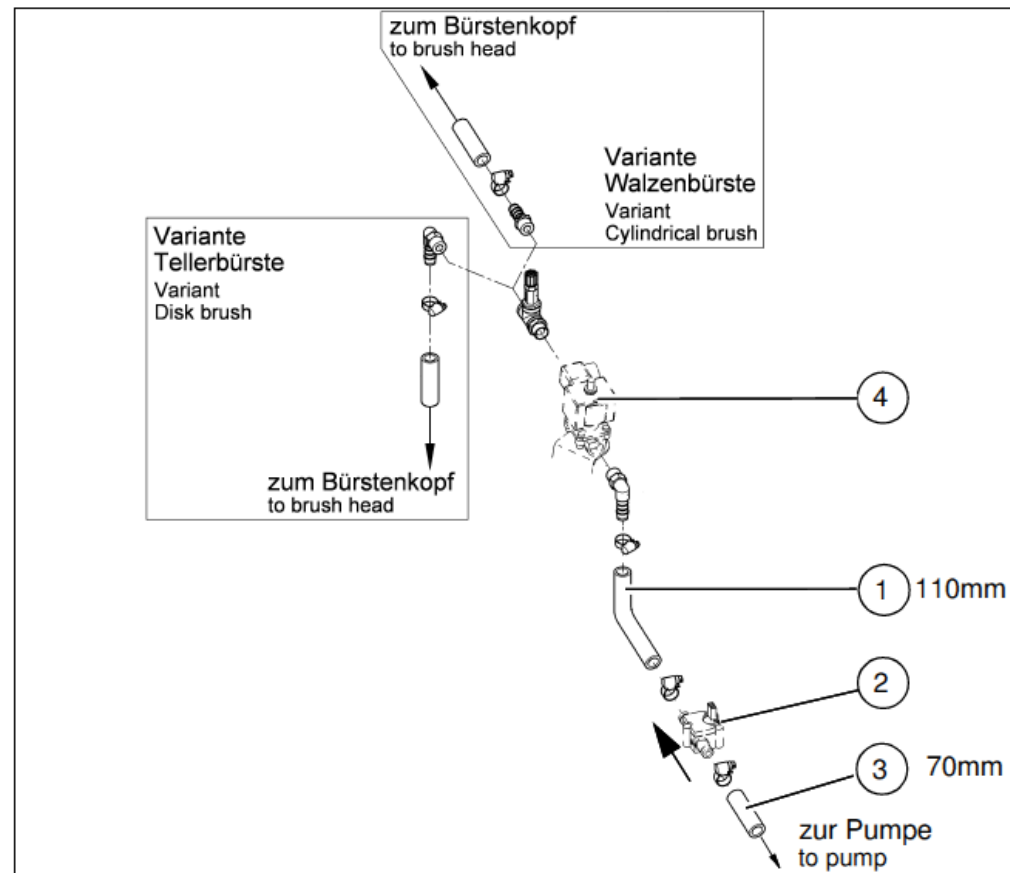

Fig. 3

12.3 Option, Chemical Dosage

1.5 Assembling the non-return valve

1. Preassemble the non-return valve (Fig. 4/1) with screw-in sockets (Fig. 4/2) and double nipple.
2. Assemble the non-return valve on the relief valve (Fig. 4/3). Max. tightening torque is 1 Nm!
3. Shorten the water hose (Fig. 4/A) between the brush head and non-return valve according to the length specification in the table and install it using hose clamps.

Brush head	Length
Disk brush head 650	260
Cylindrical brush head 700	140
Disk brush head 750	230
Cylindrical brush head 850	140
Disk brush head 900	220



Seal all the connections with three layers of teflon.

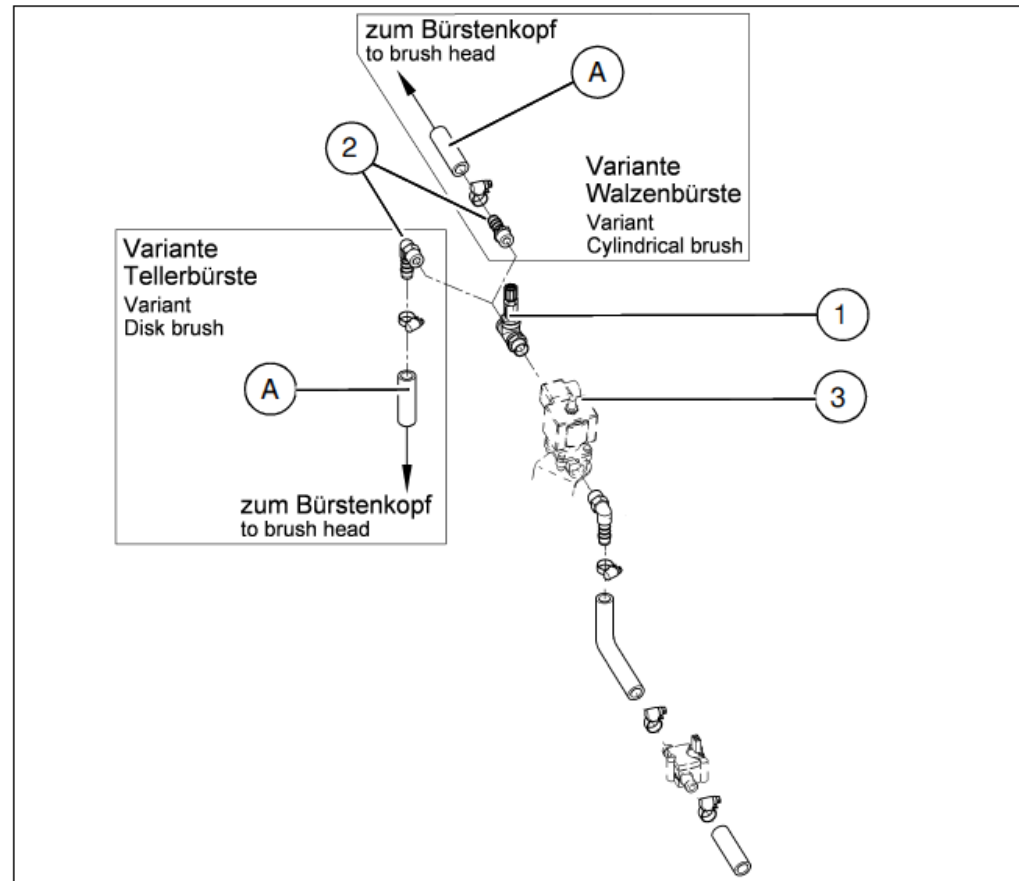

Fig. 4

12.3 Option, Chemical Dosage

1.6 Assembling the dosing hose

1. Drill a 6 mm diameter hole in the canister cap (Fig. 5/1) for the dosing hose.
2. Drill a 2 mm diameter hole in the cap for pressure compensation.
3. Fix the dosing hose, 1280 mm long, from the canister (Fig. 5/1) to the dosing pump (Fig. 5/2) (input=A) to the canister holder with cable clips and cable ties.
4. Fix the dosing hose, 1700 mm long, from the dosing pump (Fig. 5/2) (output=B) to the non-return valve (Fig. 5/3) together with the cabling using cable ties.

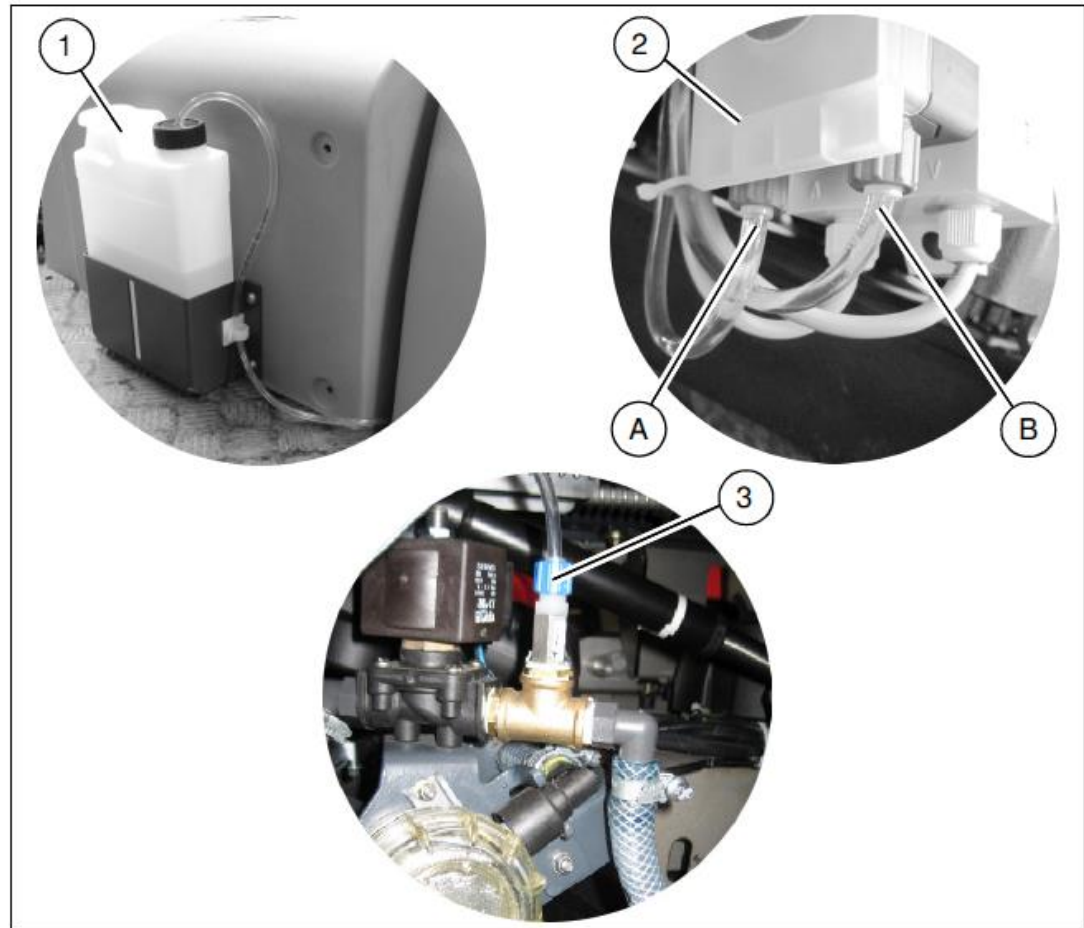

Fig. 5

12.3 Option, Chemical Dosage

1.7 Assembling the relay

1. Open the electrical box cover (Fig. 1/4).
2. Assemble the holder (Fig. 6/1) for the relay socket to the plate (Fig. 6/2). Plug the relay (Fig. 6/3) in the relay socket.

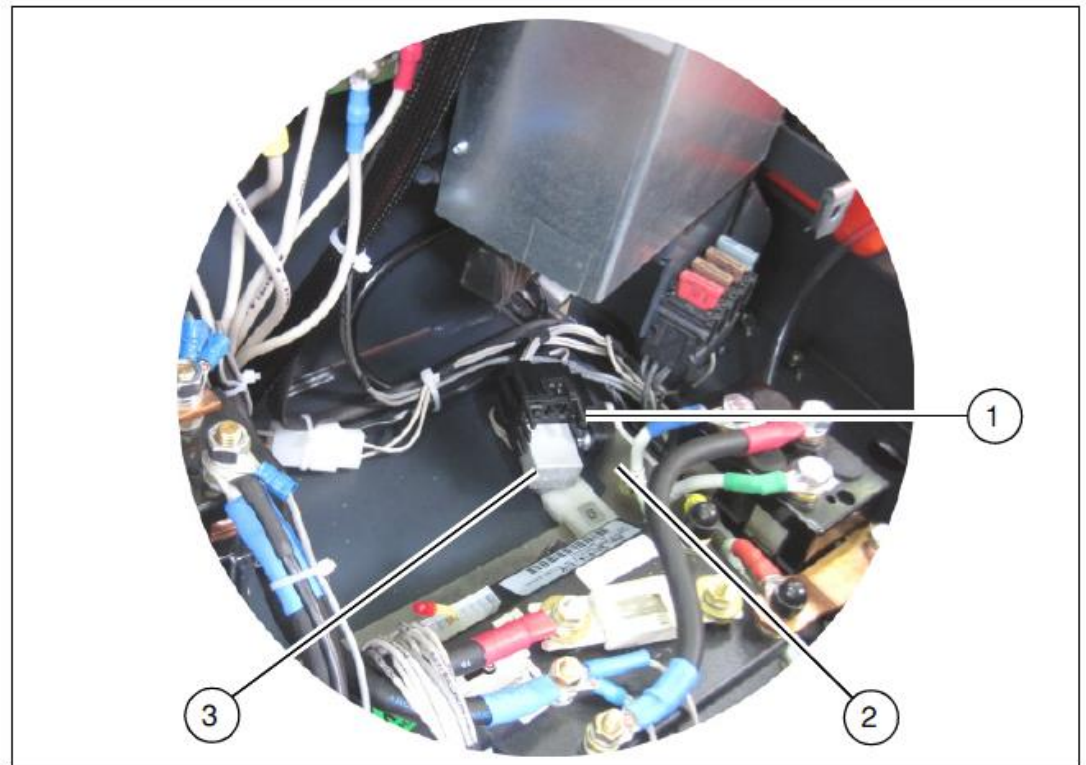

Fig. 6

12.3 Option, Chemical Dosage

1.8 Laying the cable harness

1. Plug contact F07 of cable harness W101 in the free slot in the right-hand, pre-assembled fuse holder.
2. Plug fuse link F07 in the free slot.
3. Connect cable harness W101 to relay K101, A04/NBatt (drive control), X37 in the electrical box and fix in place with cable ties. Fix X37 with cable ties.

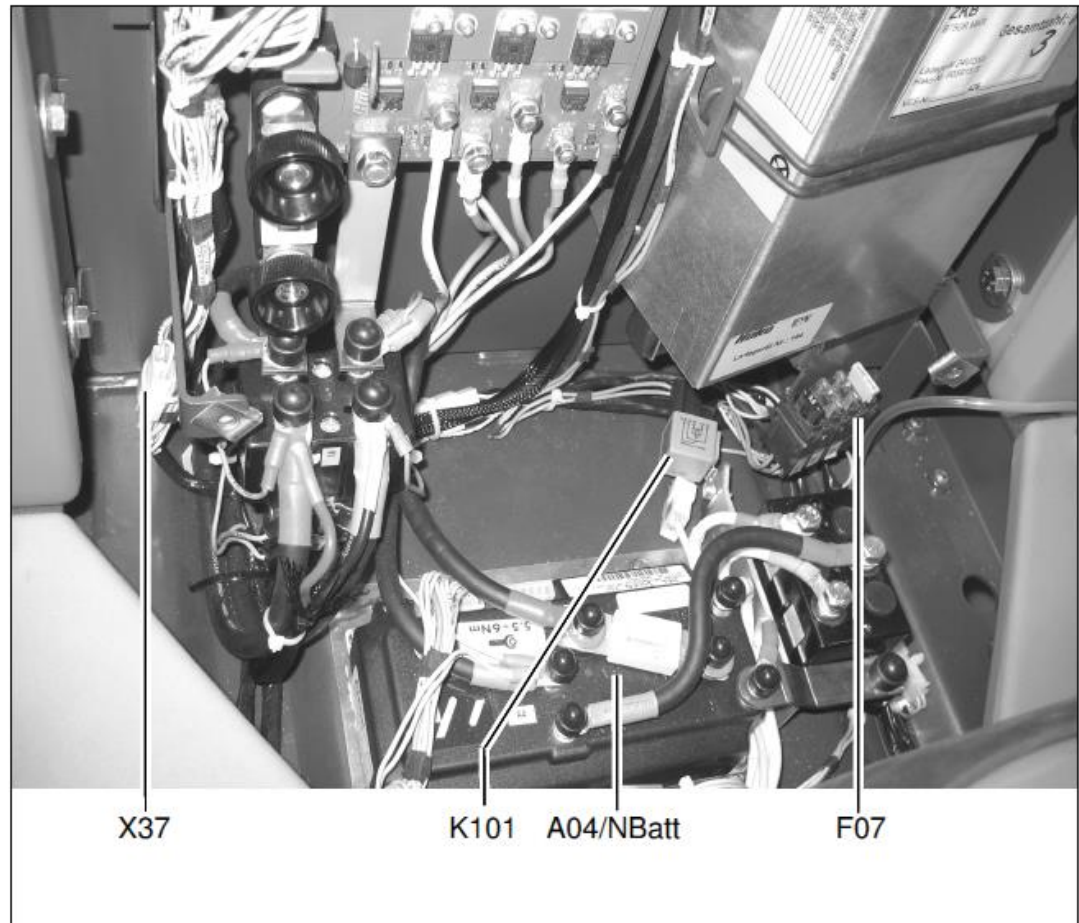

Fig. 7

12.3 Option, Chemical Dosage

4. Feed the dosing pump connection cable and hose through the hole in the chassis (Fig. 8/1) to the electrical box.
5. Connect the dosing pump connection cable with cable harnesses W101 (X103) and W102 (X104) in the electrical box and fix in place with cable ties.
6. Lay cable harness W102 and the silicone hose in the cable duct (Fig. 8/2) illustrated and fix in place with cable ties.
The cable harnesses and silicone hose must not be jammed when the battery is inserted!
7. Connect cable harness W102 to the flow meter and fix the grommet with cable ties.
8. Fix cable harness W102 to the existing cable harness (Fig. 8/3) using cable ties.

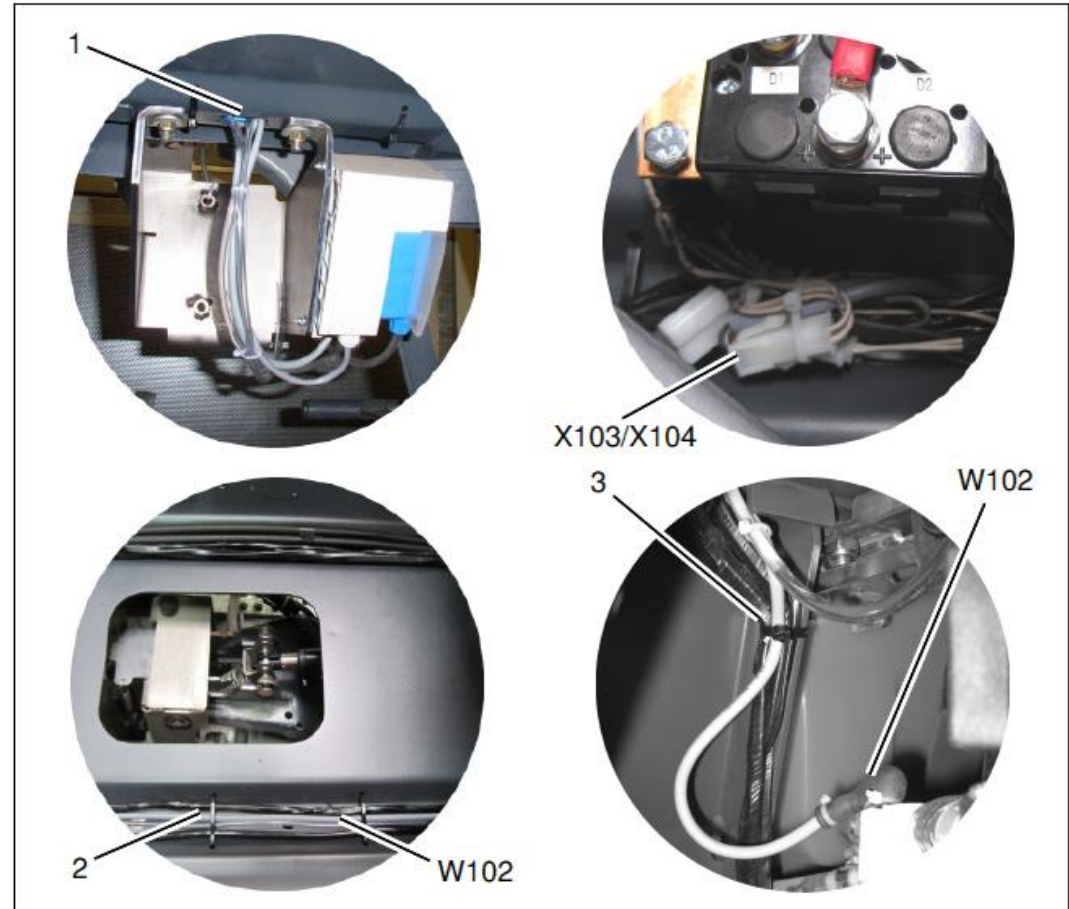
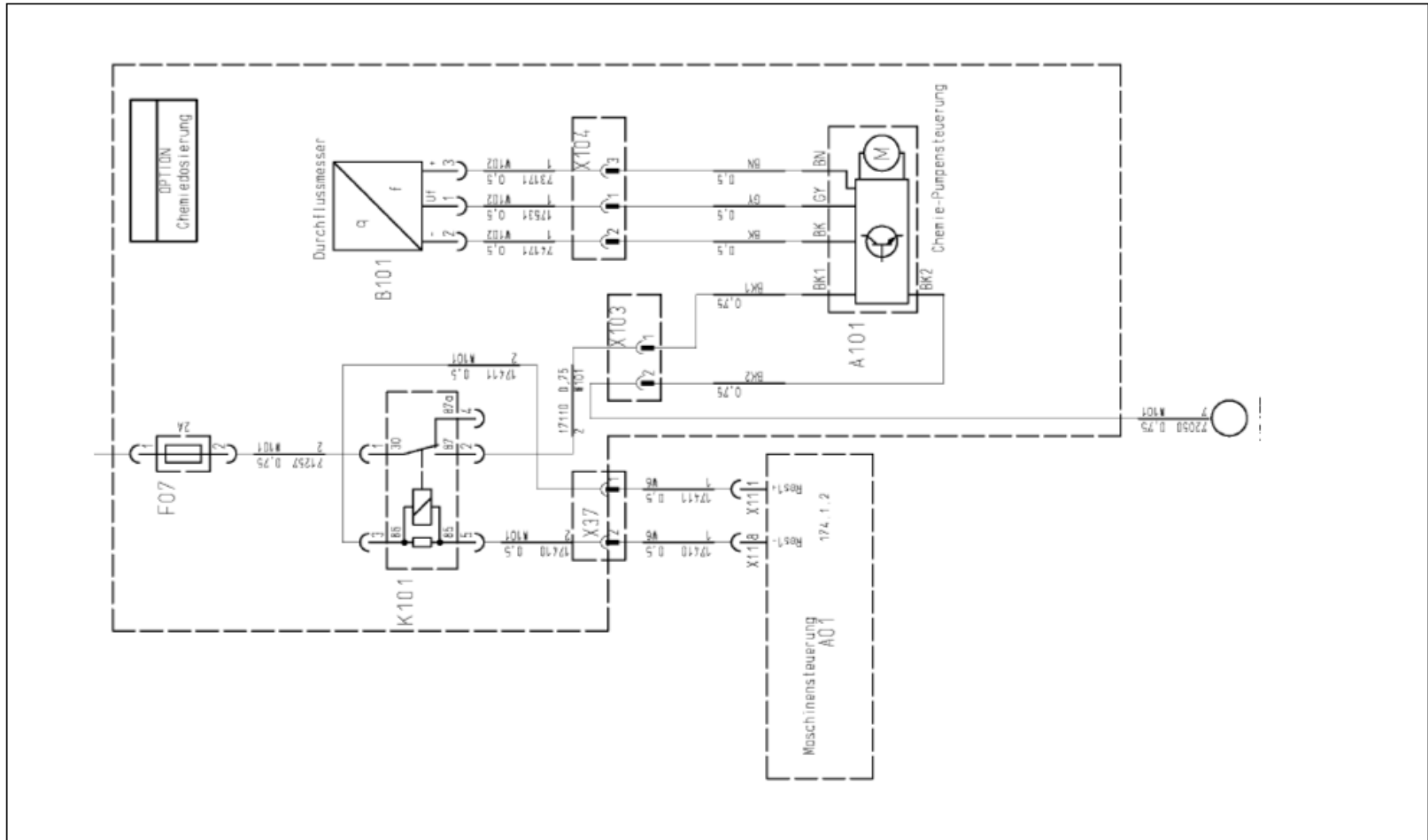

Fig. 8

12.3 Option, Chemical Dosage

1.10 Circuit diagram



12.3 Option, Chemical Dosage

1.11 Operation

Starting up

1. Fill the chemical canister with cleaning agent.
2. Switch on the key switch.
3. Switch on the dosing pump switch.
4. Press the quick fill switch (Fig. 10/1) on the dosing pump until the chemical is at the non-return valve.

Adjusting the mixture ratio

1. Remove the gray cover (Fig. 10/2) from the dosing pump.
2. Adjust the mixture ratio according to the cleaning agents used.
3. Basic setting = 1:700
Set rotary knob (Fig. 10/3) between positions 1 and 2, refer to table.

Maintenance

Check the hose section (Fig. 10/4) in the hose pump (length approx. 23mm) and replace, if necessary.

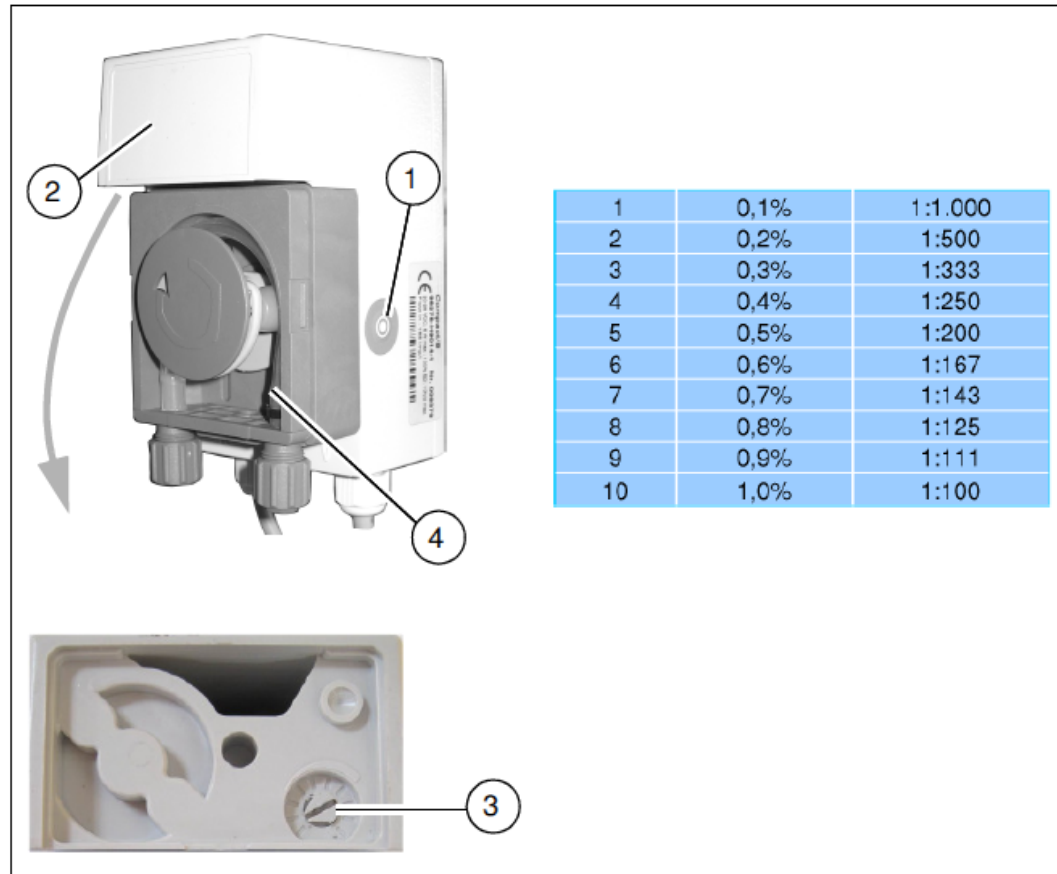

Fig. 10

12.4 Option, Scrubbing-Vacuum Tool

To activate the Scrubbing-Vacuum Tool option, access the programming level as described in Chapter 2.2.4. Then define the parameter settings as indicated in the table below and save the settings.

Chapter	Configuration	Contents	Description	B115 / PB650	B115 / PB750 / CB700	B115 / PB900 / CB850
				99-7090-51	99-7090-11 / 21 / 35 / 41	99-7090-81 / 91
1	3		TOOL			
1	3	0	Not available	d	d	d
1	3	1	Available	x	x	x

12.4 Option, Scrubbing-Vacuum Tool

Toolkit

Mechanical assembly



Switch the vehicle off and disconnect the battery plug before beginning assembly work!

Cut the hose between the water pump and solenoid valve to the specified value and connect the T-piece (Fig. 1/1) from the scope of delivery.

Then connect the tool connection hose to the quick coupler (Fig. 1/2) and fix in place.

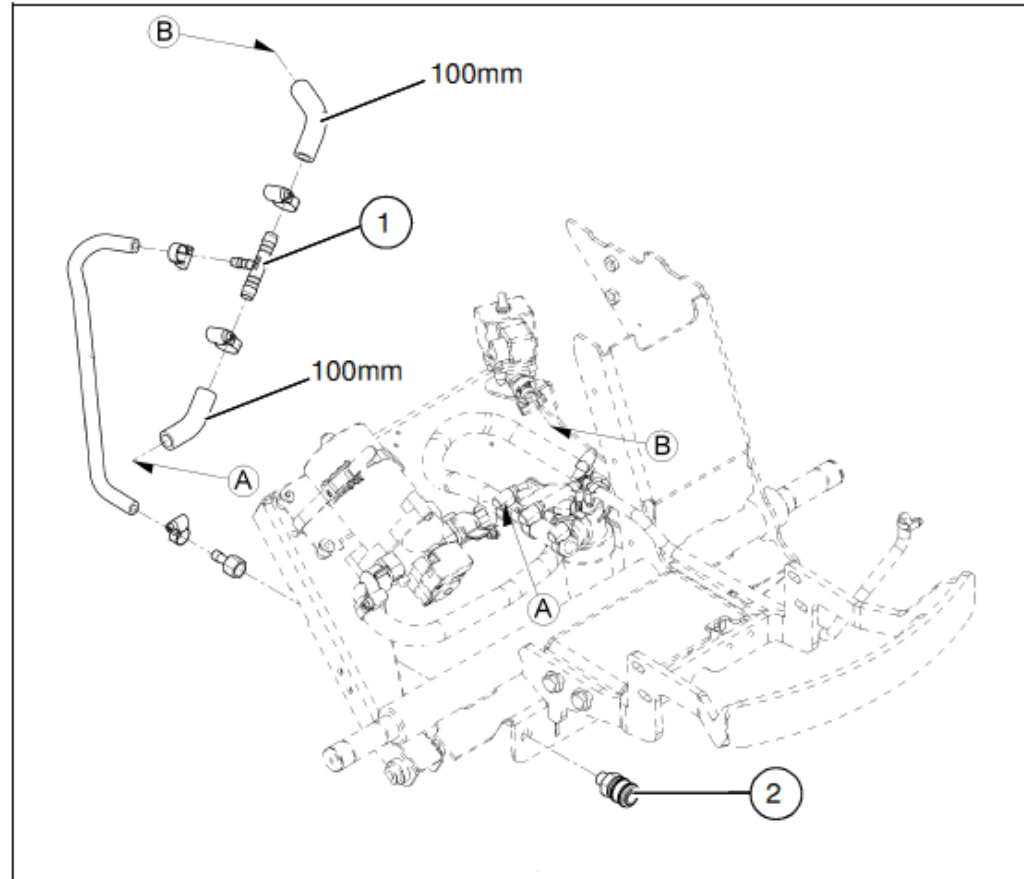

Fig.1

12.4 Option, Scrubbing-Vacuum Tool

Electrical assembly

Assembling the button

1. Feed the button (Fig. 2/1) through the cutout in the operating panel. Screw the button in place.
2. Fix the cable from the button to the existing cable harnesses (Fig. 2/2) using cable ties (the cable from the button must not be under strain).

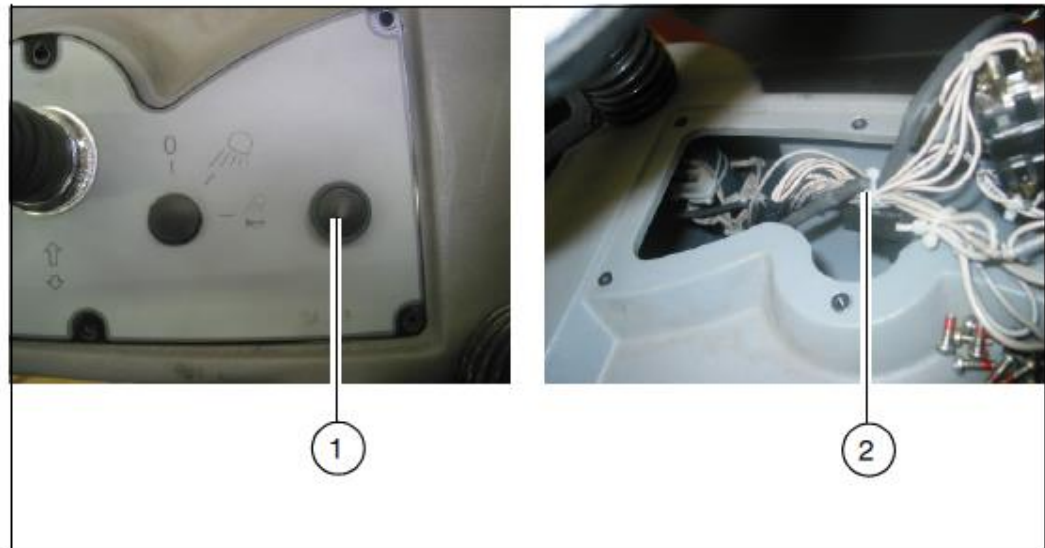

Fig.2

12.4 Option, Scrubbing-Vacuum Tool

Cable harness -W20

Cable harness -W20 is mounted in the Hakomatic B115R:

997090-11 / -21 -35/ -36/ -38/ -41/ -48/
-51 / -81 / -91

1. Connect plug connector –X26 on cable harness -W20 to the plug connector of the button.
2. Connect cable harness -W20 to the operating panel control unit -A02.X6.



Cable harness –W13 is not used!



Fig.4

12.4 Option, Scrubbing-Vacuum Tool

Operation

Toolkit button

A floor scrubbing and vacuuming tool (option) can be deployed in conjunction with the scrubbing-vacuum tool to apply and vacuum up cleaning solutions in areas difficult to access.

Hakomatic B115R:

The (Fig. 6/2) icon appears when the (Fig. 6/1) button for the toolkit is switched on.

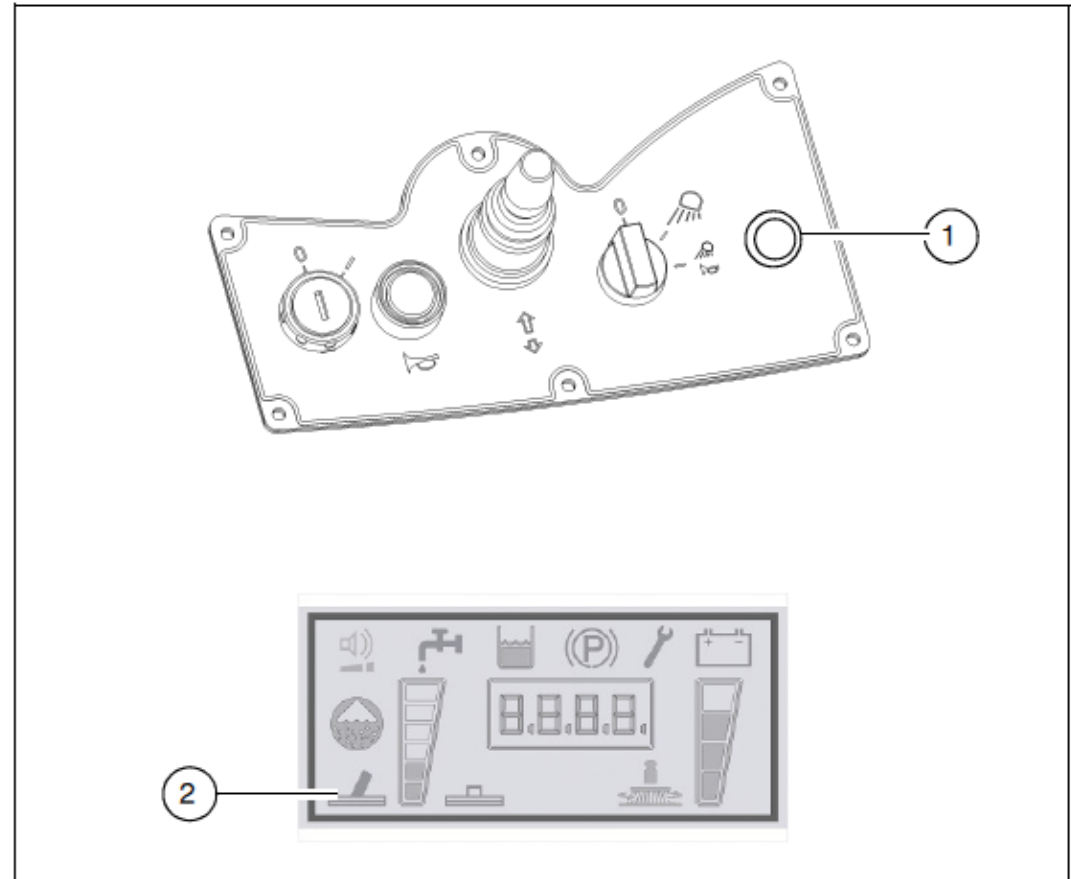

Fig.6

13. Real-Time Clock (RTC)

The Hakomatic B115R is equipped with a real-time clock which is integrated in the vehicle's control system. When the vehicle is switched off, the clock is supplied with power from a backup battery on the control electronics. Proceed as follows to set the clock, e.g. after changing the battery:

- Plug diagnostics connector PN 03006790 on connector -A1.X3 (Fig. 2.2). Without the diagnostics connector, the date and time can only be viewed, not changed.

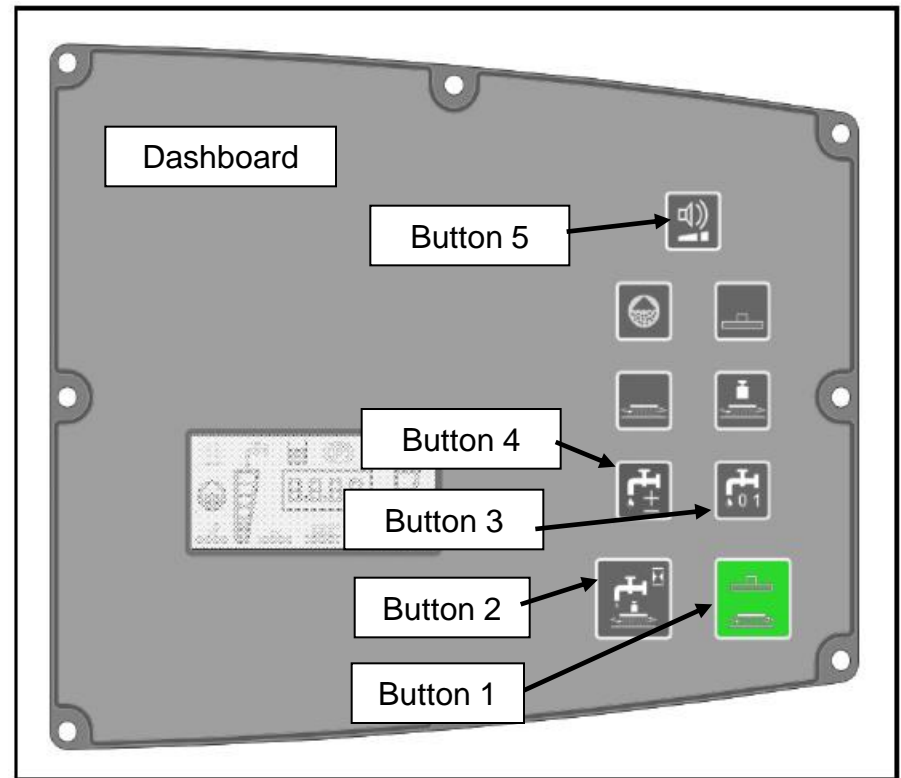

Fig. 13.1

13. Real-Time Clock (RTC)

- In order to access the Setup menu, press and hold Button 1 and Button 2 simultaneously while the key switch is switched on.
After approx. 3 seconds, the year setting appears in the operating hour counter. (In the example, 11 for 2011). Release the buttons.
- Then press Button 1 to access the settings for month, day, hour, minute and second and finally back to year.
The example shows 9 May 2011 at 11:05:25

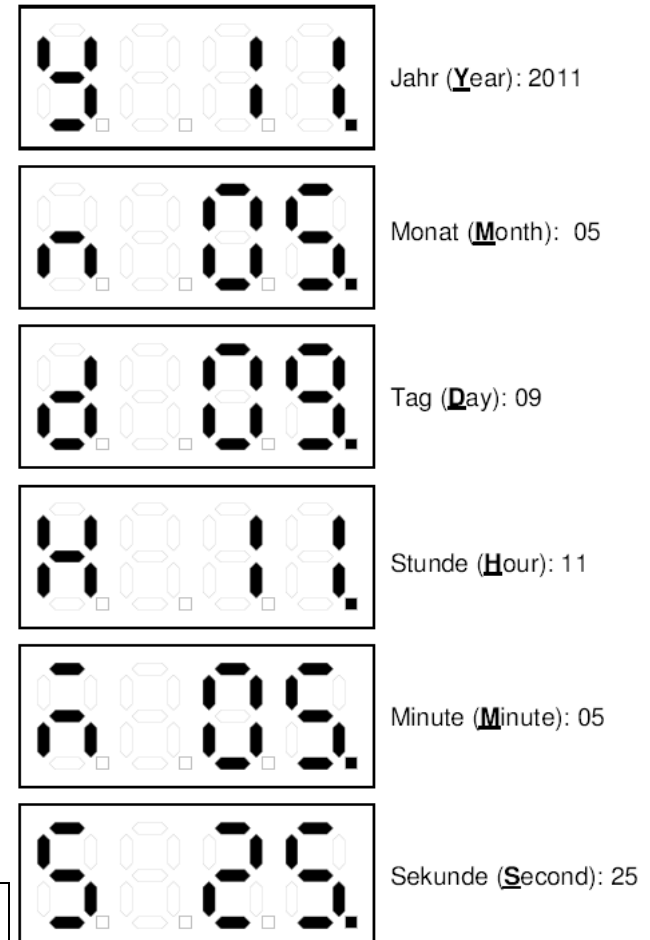

Fig. 13.2

13. Real-Time Clock (RTC)

- The value in the respective display can be increased by pressing Button 3 once or reduced by pressing Button 4 once. If the respective button is pressed and held for longer than one second, the value changes automatically at a constant speed.
- If a value is modified, the point at the bottom right behind the number disappears.
- After pressing Button 5 for three seconds, the adjusted value is saved and the point at the bottom right behind the number reappears.
- Exit from the menu by switching the engine off.
- The settings can also be set using the HAKO diagnostics system.

14. Notes

14. Notes

14. Notes